



BT8376

SYSTEM X™

FREESTANDING CURVED VIDEO WALL STAND INSTALLATION GUIDE & PARTS LIST

This Pack Contains 1 Stand

PLEASE KEEP THIS FOR FUTURE REFERENCE

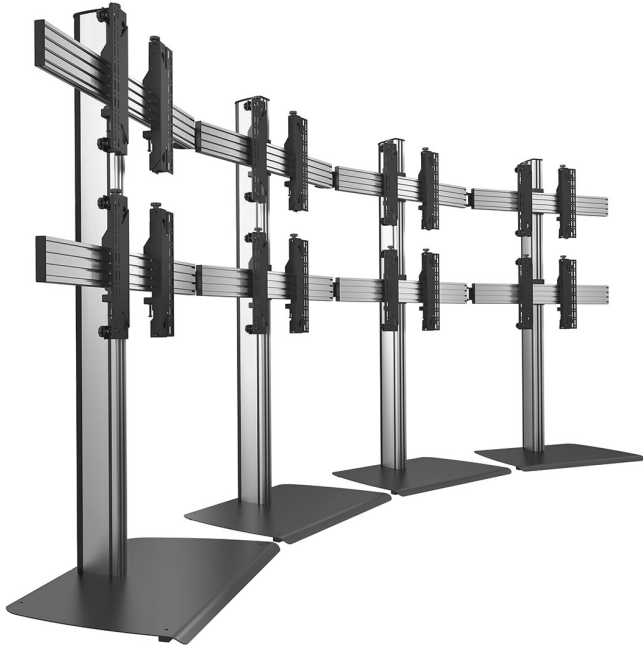

FEATURES

- Universal design suitable for all videowall screens
- Suitable for videowall screens from 39" - 70"
- Max weight per screen: 50kg (110lbs)
- Designed for screens with VESA® & non-VESA mounting patterns
- Tool-less micro-adjustments for seamless screen alignment
- Easy to use angle adjustment with a range up to +/-45°
- Universal screen position spacer to speed up the installation process
- Integrated cable management
- Safety screws help prevent unauthorised removal of screens



Per Screen

CONTENTS

Installation Safety Notes.....	2
Parts List.....	4
Optional Accessories.....	6
Installation Instructions.....	8
B-Tech Contact Details.....	24

INSTALLATION TOOLS REQUIRED

Crosshead screwdriver



10mm Spanner



Level



Knife



B-TECH AV MOUNTS

www.btechavmounts.com

INSTALLATION SAFETY INSTRUCTIONS



CAUTION: This stand is intended for use only with the maximum weights indicated. Use with flat screens heavier than the maximum indicated may result in instability causing possible injury.

Do not attempt to install this product until all instructions and warnings have been read and properly understood. Please keep these instructions for future reference.

Please check carefully to make sure there are no missing or defective parts - defective parts must never be used. B-Tech International Design & Manufacturing Ltd, its distributors and dealers are not liable or responsible for damage or injury caused by improper installation, improper use or failure to observe these safety instructions. In such cases, all guarantees will expire.

General

Great care must always be taken during installation as most AV equipment is of a fragile nature, possibly heavy and easily damaged if dropped.

If you do not fully understand the instructions or are not sure how to install this product safely, then please consult a professional for advice and/or to install this product for you. Failure to mount this product correctly may cause serious injury or death both during installation and at any time thereafter. Do not mount any AV equipment that exceeds the specific weight limit of the product you are installing. This weight limit will be clearly stated on each product and its packaging and will vary from product to product.

Product location

Please pay careful attention to where this product is located, some locations are not suitable for installation. For indoor use only. Install stand on level ground. When verifying the stability of the structure, consider the following external factors: The strength of the floor, exposure to sudden and severe wind and danger arising from contact with people and / or objects (eg installations in passageways, emergency exits), if located in a public or frequently populated area ensure that the product is out of the immediate reach of people.

Fixing hardware

It is highly recommended that all fixing screws be used where supplied and that the purpose of all other fixing hardware is fully understood. In some cases more AV equipment fixing hardware will be supplied to accommodate different models of equipment and set up configurations.

The installer must be satisfied that any supplied fixing hardware is suitable for each specific installation. If any fixing screws or included hardware are deemed not sufficient for a safe installation then please consult a professional or your local hardware store.

Hazard limitation

When routing cables take advantage of any built in cable management features that the product might provide and ensure that all cables are tidy and secure. Check to see that any moving aspect of the product can do so unhindered by any cabling.

Some products have moving parts and the potential to cause injury through the crushing or trapping of fingers or other body parts.

Particular attention to the nature of moving parts is required especially when assembling installing and adjusting during set up.

Immediately after installations double-check that the work done is safe and secure. Double-check all necessary fixings are present and are of ample tightness.

It is recommended that periodic inspections of the product and its fixing points are made as frequently as possible to ensure that safety is maintained. If in doubt consult a professional AV installer or other suitably qualified person.

CS

Společnost B-Tech International Design And Manufacturing Ltd. doporučuje provést instalaci tohoto produktu instalátora AV či jinak způsobilé osoby. Společnost B-Tech International Design And Manufacturing Ltd, její distributoři a prodejci nenesou prostřednictvím odborného odpov ědnost za škody nebo zranění způsobená nevhodnou instalací. Tento výrobek je nutno umístit do vhodné konstrukce a používat jen po uvedené maximální výšce.

DE

B-Tech International Design And Manufacturing Ltd. empfiehlt, dass dieses Produkt durch einen qualifizierten AV-Techniker oder eine andere Person mit geeigneter Qualifikation installiert wird. B-Tech International Design And Manufacturing Ltd, ihre Distributoren und Händler können nicht für durch fehlerhafte Montage verursachte Beschädigung oder Verletzung haftbar bzw. verantwortlich gemacht werden. Dieses Produkt muss auf eine geeigneten Untergrund montiert werden und darf nur bis zum angegebenen Höchstgewicht verwendet werden.

ES

B-Tech International Design And Manufacturing Ltd. recomienda que un instalador de audio y video profesional u otra persona debidamente cualificada instalen este producto. B-Tech International Design And Manufacturing Ltd, sus distribuidores y concesionarios no se hacen cargo ni se responsabilizan de ningún daño o lesión provocados por una instalación inapropiada. Este producto se debe montar en una estructura adecuada y se debe utilizar soportando solamente hasta el peso máximo indicado.

FR

B-Tech International Design And Manufacturing Ltd. recommande de confier l'installation de ce produit à un installateur AV professionnel ou à une autre personne dûment qualifiée. B-Tech International Design And Manufacturing Ltd, ses distributeurs et ses revendeurs ne sauraient être tenus responsables de tout dégât ou de toute blessure résultant d'une installation incorrecte. Ce produit doit être monté sur un support approprié et utilisé dans la limite du poids maximum indiqué.

IT

B-Tech International Design And Manufacturing Ltd. consiglia di affidare l'installazione di questo prodotto a un installatore specializzato o ad altra persona adeguatamente qualificata. B-Tech International Design And Manufacturing Ltd. i suoi distributori e rivenditori non accettano alcuna responsabilità nei riguardi di eventuali danni o infortuni causati da un'errata installazione. Questo prodotto deve essere fissato a una struttura idonea e utilizzato unicamente sino al peso massimo indicato.

NL

B-Tech International Design And Manufacturing Ltd. adviseert om dit product te laten installeren door een professionele AV-instalateur of andere hiervoor gekwalificeerde persoon. B-Tech International Design And Manufacturing Ltd, haar distributeurs en dealers zijn niet aansprakelijk of verantwoordelijk voor schade of letsel die is veroorzaakt door onoordeelkundige installatie. Dit product moet worden gemonteerd aan een geschikte constructie, waarbij het aangegeven maximum gewicht niet mag worden overschreden.

PL

Firma B-Tech International Design And Manufacturing Ltd. zaleca, aby ten produkt był instalowany przez profesjonalnych instalatorów AV lub inny odpowiednio przeszkolony personel. Firma B-Tech International Design And Manufacturing Ltd, jej dystrybutorzy i dealerzy nie ponoszą odpowiedzialności za uszkodzenia lub obrażenia ciała powstałe w wyniku nieprawidłowej instalacji. Niniejszy produkt musi być zamontowany na odpowiedniej powierzchni, a podczas u żytkowania nie wolno przekraczać podanego maksymalnego obciążenia.

PT

A B-Tech International Design And Manufacturing Ltd. recomenda que a instalação deste produto seja efectuada por um instalador de AV instalador de AV profissional ou outra pessoa devidamente habilitada. A B-Tech International Design And Manufacturing Ltd. e os seus distribuidores e concessionários não são responsáveis por danos ou lesões causados por uma instalação incorrecta. Este produto tem de ser montado numa estrutura adequada e utilizado somente até ao peso máximo indicado.

RU

Компания B-Tech International Design And Manufacturing Ltd. рекомендует, чтобы установка данного изделия производилась инженером по установке аудио-видеотехники или другим специалистом с соответствующей квалификацией. Компания B-Tech International Design And Manufacturing Ltd. ее дистрибьюторы и дилеры не несут ответственности за повреждения или травмы, полученные в результате неправильной установки. Данное изделие должно

توصي بي- تك للتجارة الدولية المحدودة بأن شخص محترف في تركيب ال AV او شخص مؤهل تأهيلا مناسباً لتركيب هذا المنتج. بي- تك للتجارة الدولية، موزعيها والتجار ليست عرضة أو مسؤولة عن الأضرار أو الإصابات الناجمة عن تركيب غير سليم، والاستخدام غير السليم أو عدم مراعاة هذه التعليمات للسلامة. يجب أن يتم تركيب هذا المنتج في بنية مناسبة ويجب استخدامه فقط لدعم الحد الأقصى للوزن المشار إليه.

BT8376 PARTS LIST

Due to the multiple installations available each option below is dependent on the stand ordered.

PLEASE KEEP THIS FOR FUTURE REFERENCE

(A) BASE

BT8380-FSB

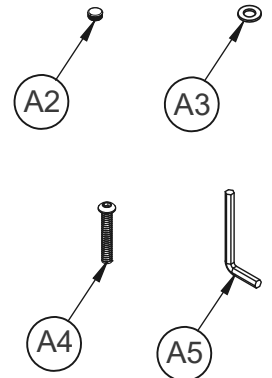
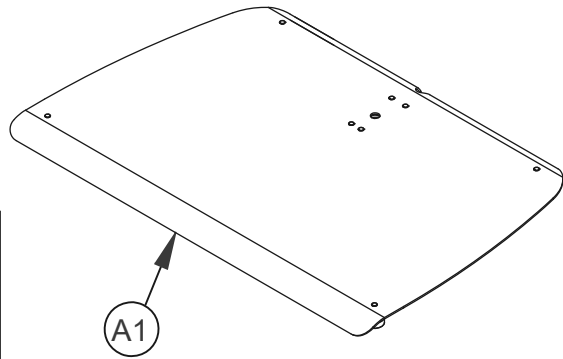

ITEM	PART NAME	QTY PER PACK
A1	BASE	1
A2	HOLE CAP	8
A3	M8 WASHER	4
A4	M8 x 50mm SCREW	4
A5	5AF HEX KEY	1

(B) COLUMN

BT8380-180
Height: 180cm

BT8380-060
Height: 60cm

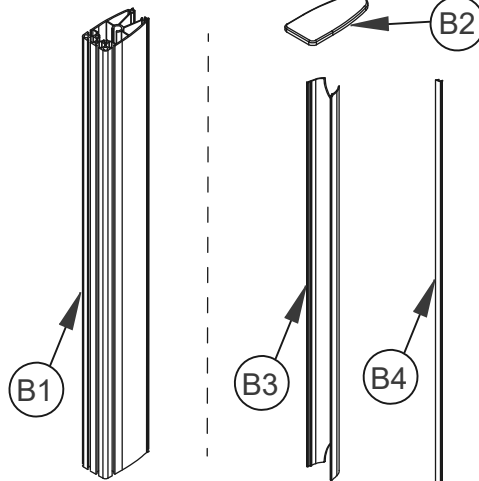

Optional
*To fix shelves to a column

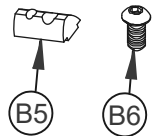

ITEM	PART NAME	QTY PER PACK
B1	VERTICAL COLUMN	1
B2	END CAP*	1
B3	CABLE COVER	3
B4	PLASTIC SLOT INSERT	4
B5	M8 SLIDING NUT*	2
B6	M8 x 12mm SCREW*	2
B7	COLUMN JOINER**	4
B8	GRUB SCREW**	16
B9	M6 x 10mm HEX BOLT**	8
B10	3AF HEX KEY**	1

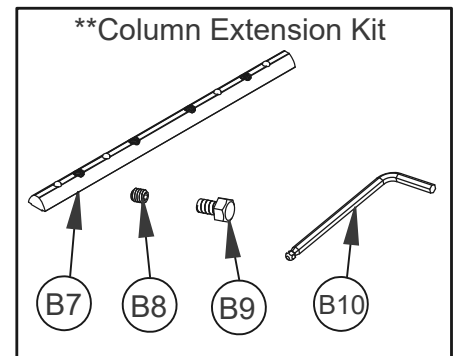

*Supplied with the BT8380-180
**Supplied with the BT8380-060

(C) JOINING PLATE

BT8380-JPK

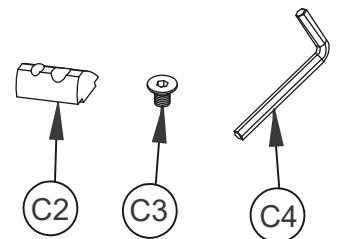
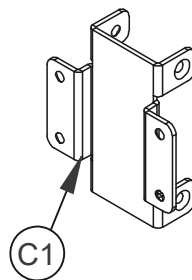

ITEM	PART NAME	QTY PER PACK
C1	JOINING PLATE	1
C2	M8 SLIDING NUT	8
C3	M8 x 12mm SCREW	4
C4	5AF HEX KEY	1

(D) MOUNTING RAIL

BT8390-050
Length: 50cm

BT8390-070
Length: 70cm

BT8390-150
Length: 150cm

BT8390-175
Length: 175cm

BT8390-200
Length: 200cm

BT8390-300
Length: 300cm

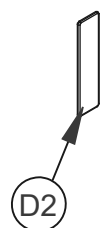
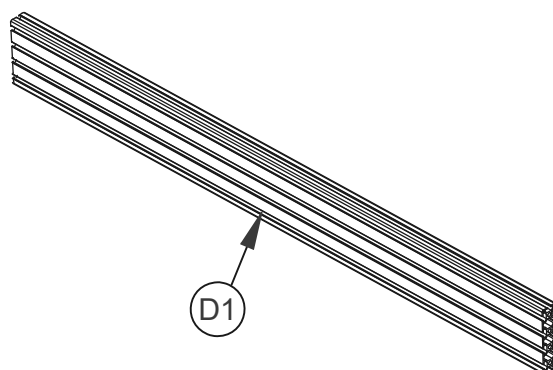

ITEM	PART NAME	QTY PER PACK
D1	MOUNTING RAIL	1
D2	END CAP	2

(E) ANGLE ADJUSTMENT CONNECTOR

BT8390-AAC

ITEM	PART NAME	QTY PER PACK
E1	ANGLE CONNECTOR	1
E2	M8 x 16mm SCREW	4
E3	M8 WASHER	12
E4	M8 x 12mm SCREW	8
E5	M8 SLIDING NUT	8
E6	5AF HEX KEY	1

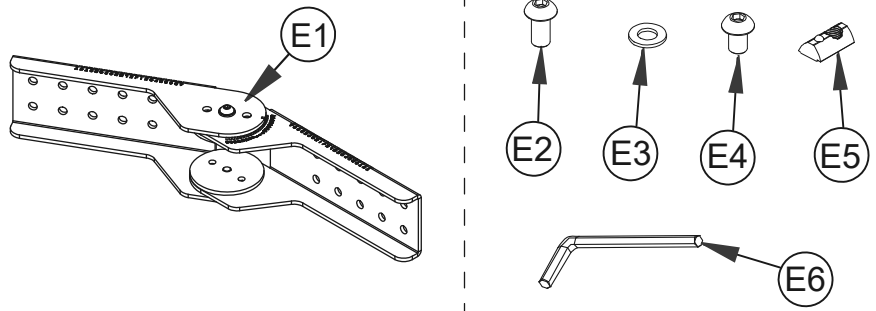

(F) SPACER

BT8390-SP

ITEM	PART NAME	QTY PER PACK
F1	SPACER	1

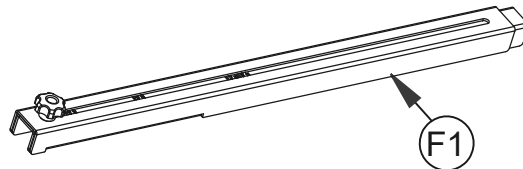

(G) INTERFACE KIT

ITEM	PART NAME	QTY PER PACK
G1	LEFT INTERFACE ARM	1
G2	RIGHT INTERFACE ARM	1
G3	ADJUSTABLE BRACE*	1
G4	M5 x 6mm SCREW*	2
G5	M6 x 35mm SCREW*	2
G6	3AF HEX KEY*	1
G7	4AF HEX KEY*	1
G8	5AF LONG HEX KEY	1

ITEM	SCREEN FIXING KIT	QTY PER PACK
A	M6 x 16mm SCREW	4
B	M6 x 25mm SCREW	4
C	M6 x 40mm SCREW	4
D	M8 x 16mm SCREW	4
E	M8 x 25mm SCREW	4
F	M8 x 40mm SCREW	4
G	5mm SPACER	4
H	13mm SPACER	4
I	24mm SPACER	4
J	M6 WASHER	4

Screen Interface Arms

BT8390-VESA400MAF

BT8390-VESA400MAP

Interface Arm Kit

Screen Fixing Kit

*Only supplied with the BT8390-VESA400MAP

(H) OPTIONAL INTERFACE ADAPTOR ARMS

BT7564 | BT7565 | BT7566

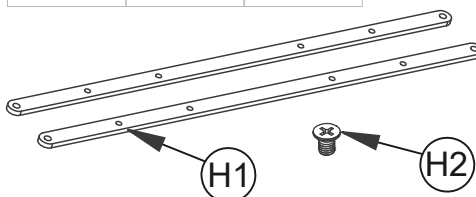

ITEM	PART NAME	QTY PER PACK
H1	ADAPTOR ARMS	2
H2	M8 x 12mm SCREW	4

INSTALLATION NOTES

FLOORSTAND STABILITY



WARNING



- Install stand on level ground
- Minimum two person assembly

When verifying the stability of the structure, consider the following external factors:

1. The strength of the floor.
2. Exposure to sudden and severe wind.
3. Danger arising from contact with people and / or objects.
(eg installations in passageways, emergency exits).

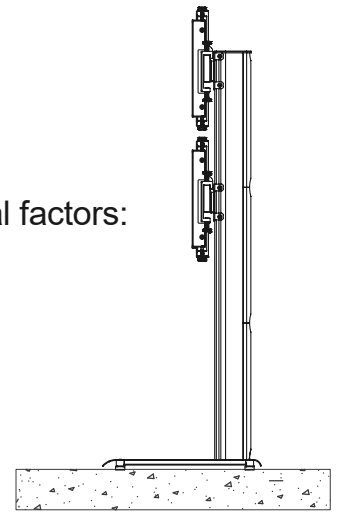

OPTIONAL ACCESSORIES

Cable Management Clip

BT8390-CMC

Attach the *BT8390-CMC* cable management clips directly to item D1 to organise screen cables for a neat and tidy installation.

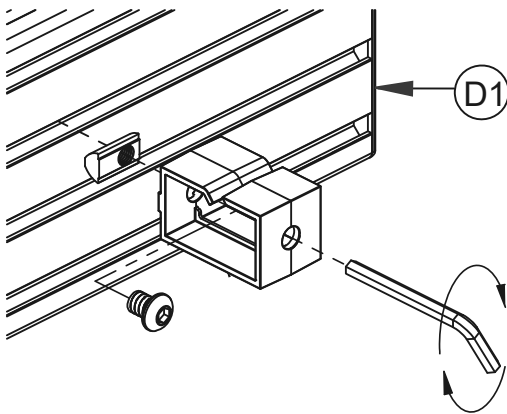

AV Component Shelves

Insert 2 x item B5 into item B1 front slots.

Mount a B-Tech Shelf (*BT7032 / BT7033 / BT7863*) by fastening item B6 to item B5.

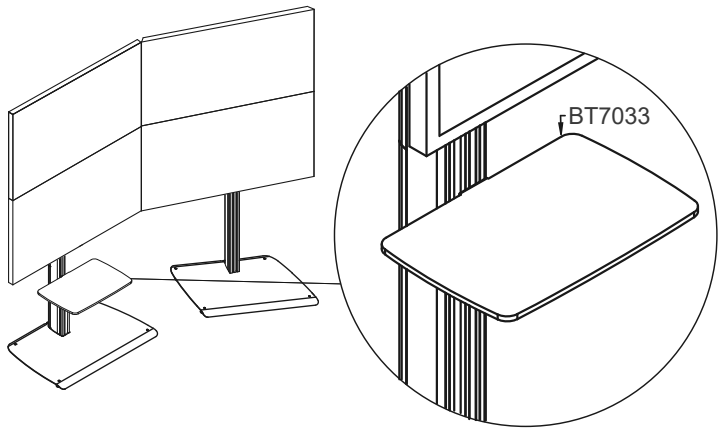

Use a *BT8390-SA* shelf adaptor to mount shelves directly under or over the horizontal mounting rails.

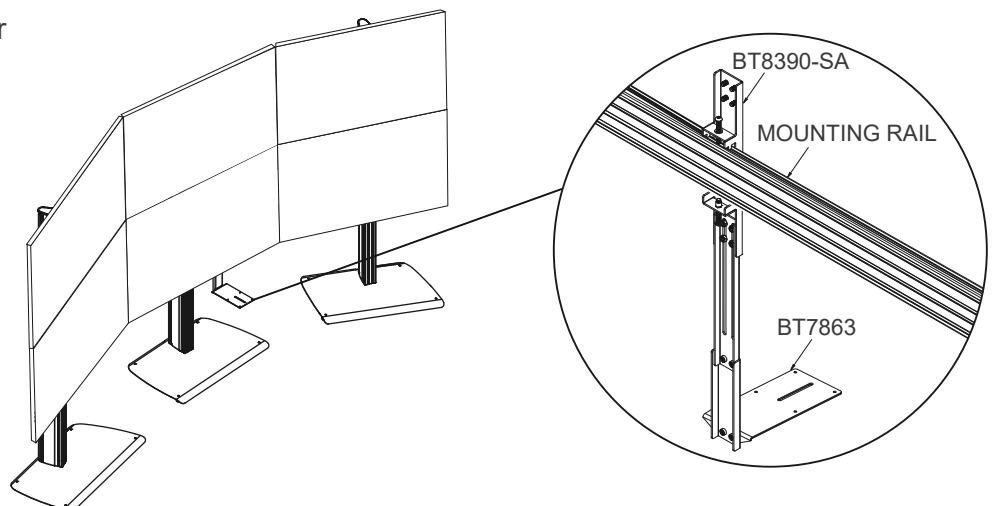

OPTIONAL: EXTENDING THE COLUMNS

- i. Insert items B7 halfway into the non-threaded end of item B1. The two joining bars with grub screws go in the front of the column and the 2 joining bars with hex bolts go in the back.

IMPORTANT: Joining bars should be inserted into the non-threaded end of the 180cm column.

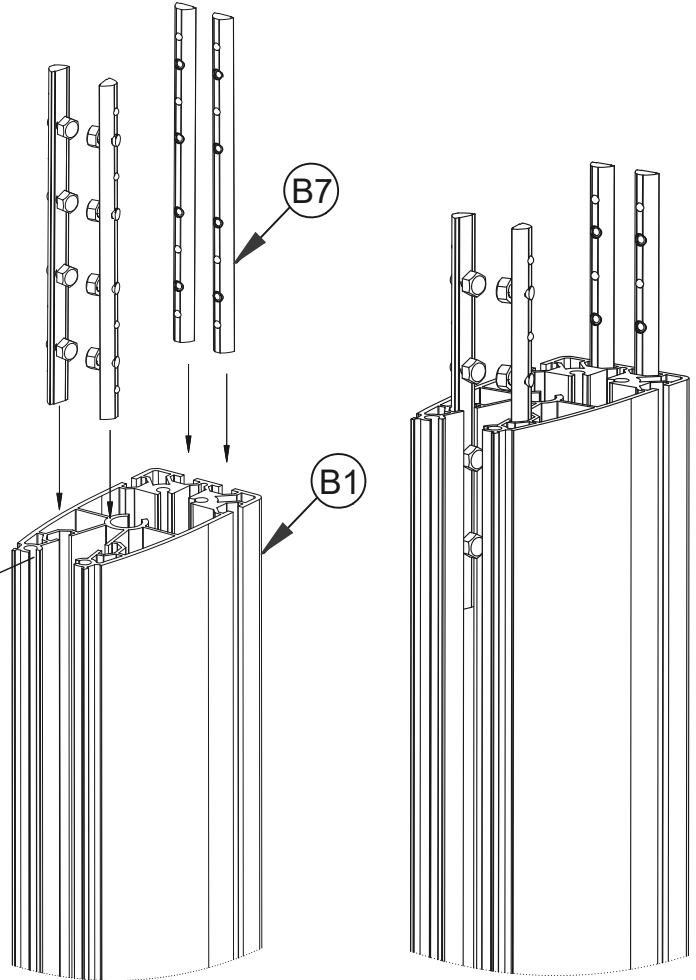
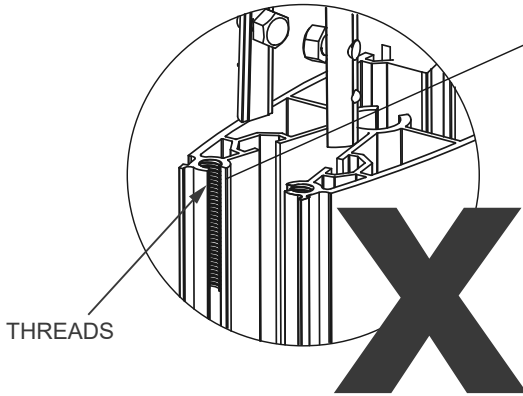

Front of Column

- ii. The two joining bars with grub screws (item B8) in the front of the column.

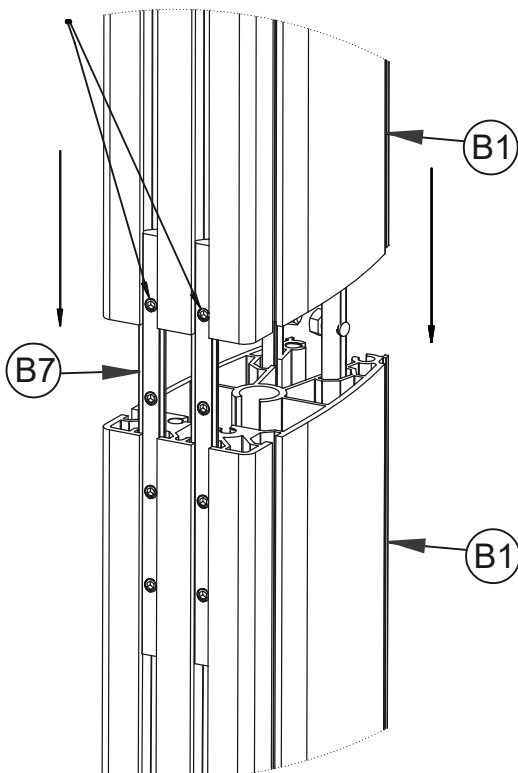

Back of Column

- The two joining bars with hex bolts (item B9) in the rear of the column.

Tighten hex bolts by hand. Finish tightening using a 10mm spanner.

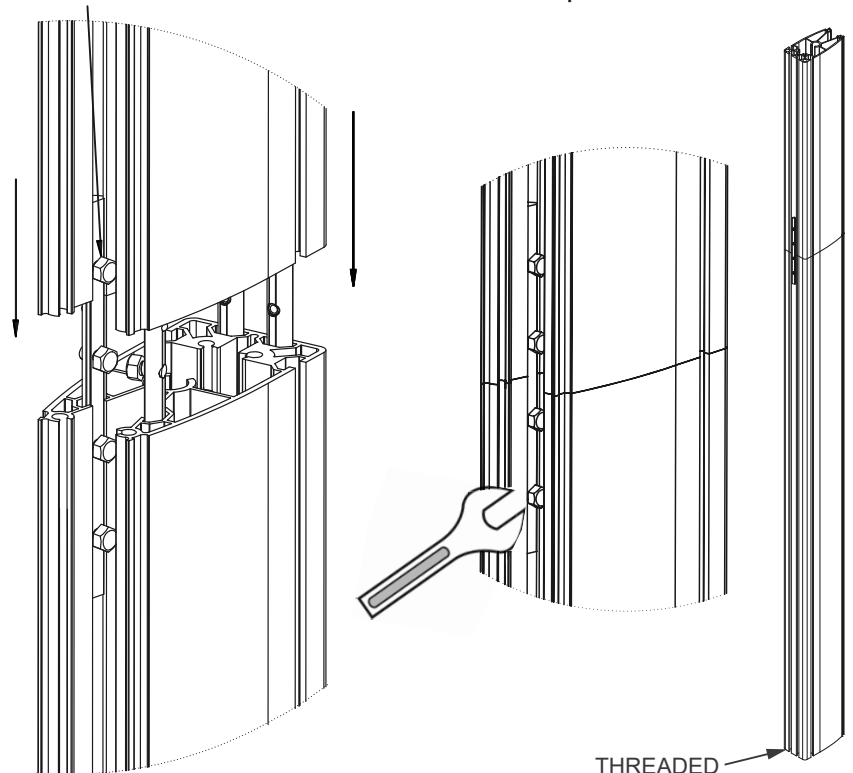

INSTALLATION INSTRUCTIONS

1

Attach Joining Plate to Column

- i. Connect together four item C3 with item C2 onto each item C1 using item C4.
- ii. Lay items B1 on the floor and slide two item C1 onto each item B1.

i.

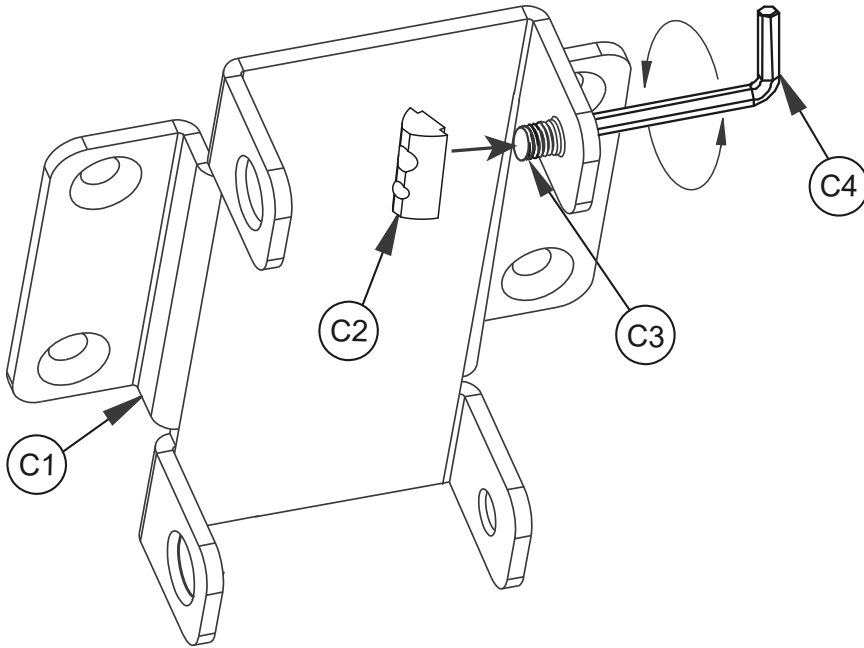

ii.

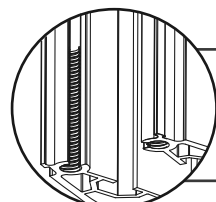
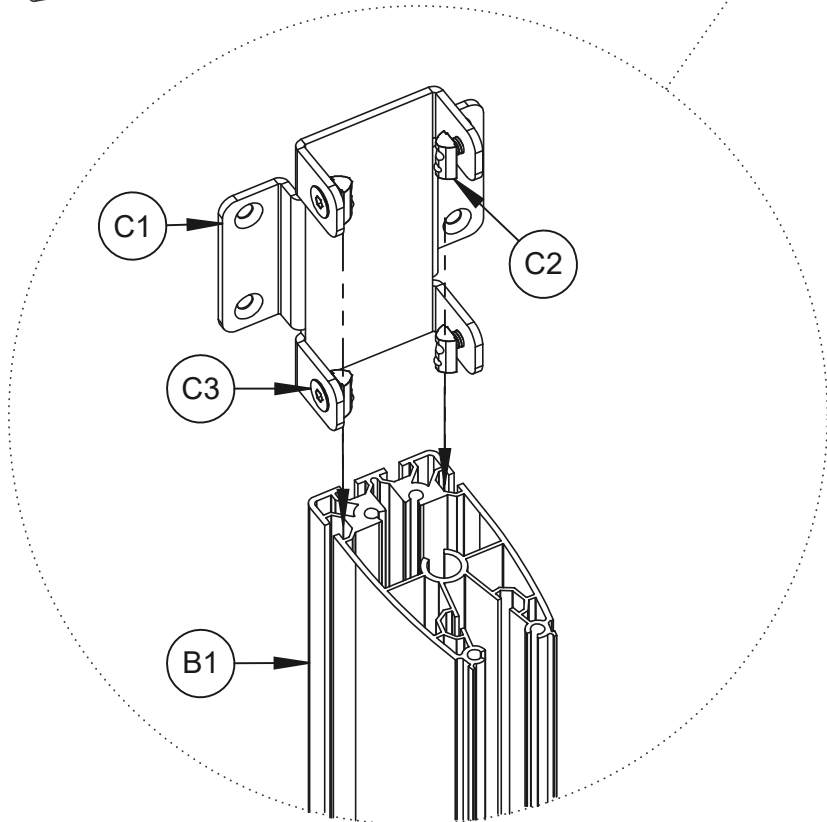
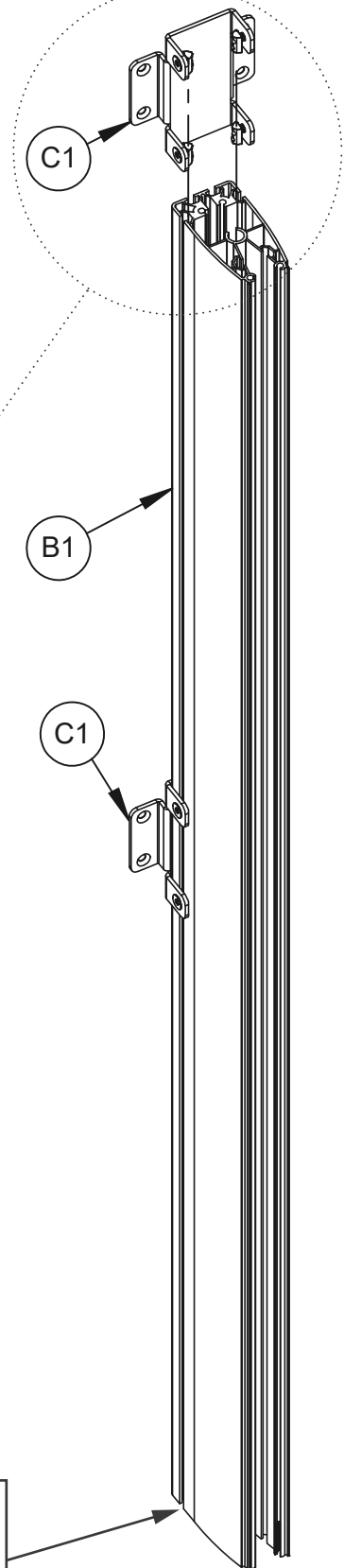

IMPORTANT:
Make sure the end with M8 threads
are at the bottom of the columns.

- iii. Use item F1 to set the distance between items C1 on item B1 according to the screen size.
Once set, tighten item C3 with item C4.

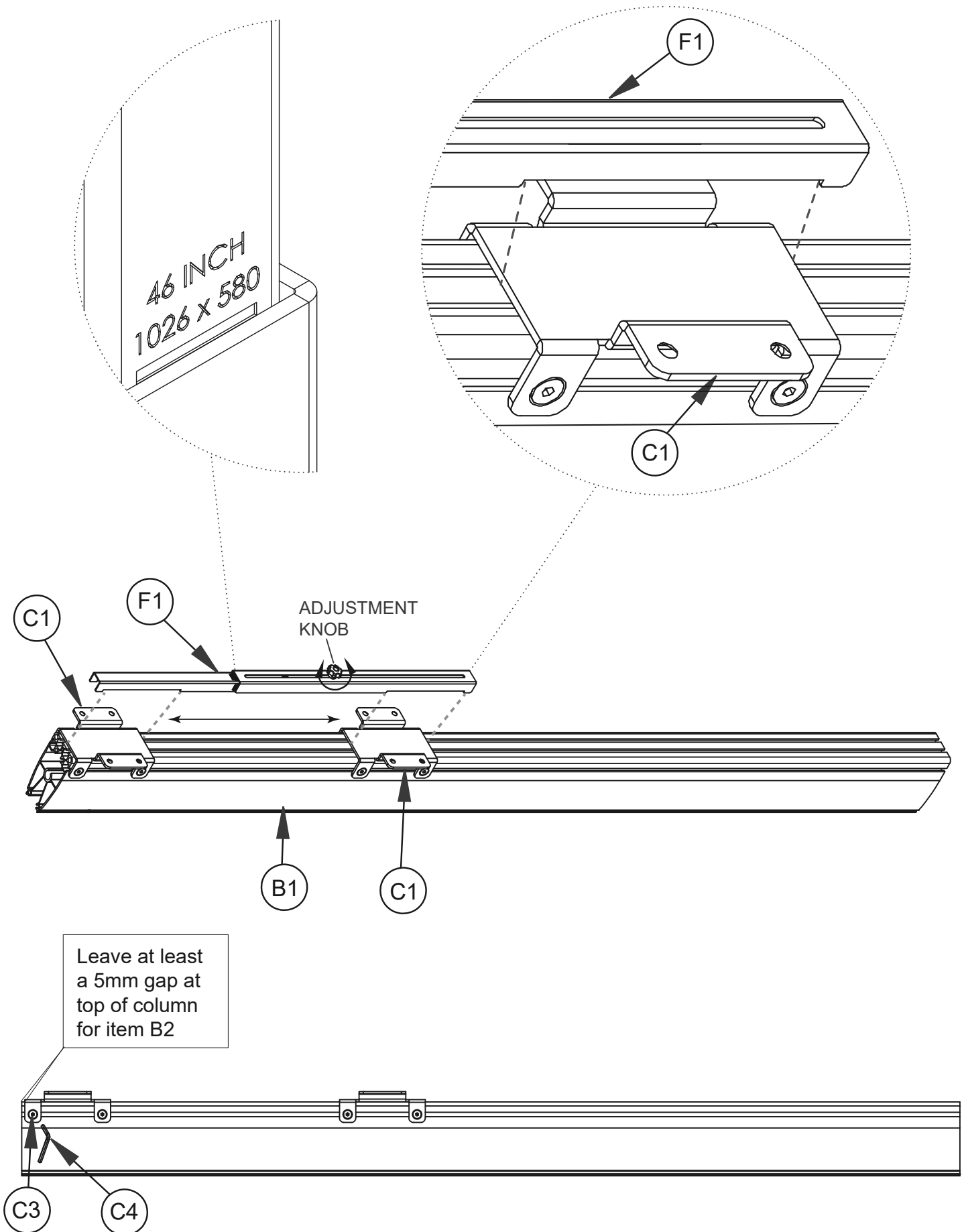

2

Insert Sliding Nuts into Mounting Rails

Lay items D1 on the floor.

For each item C1 attachment insert 4 x item C2 into item D1. Two in the 2nd slot and two in the bottom slot.

To attach item E1 to item D1, insert 4 x item E5 into the end of the rail. Two in each centre slot.

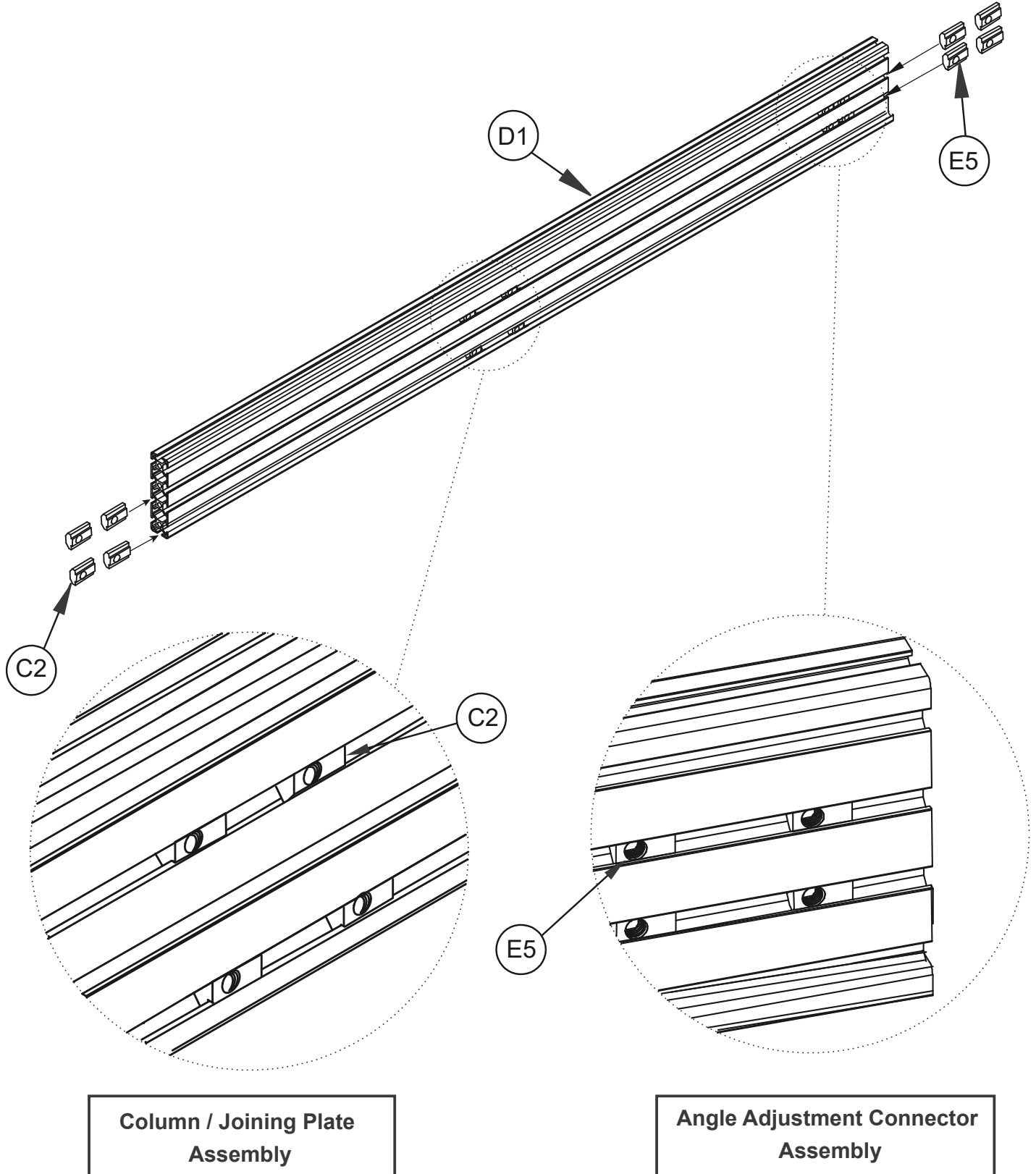

Connect Rails Together using the Angle Adjustment

- i. Assemble items E2 and E3 to item E1. *Do not fully tighten the screws and washers.*
- ii. With the rails flat on the floor, fix item E1 to 2 x item D1 using items E3, E4 and E5. Make sure all rails are fixed using the same positions on item E1*.

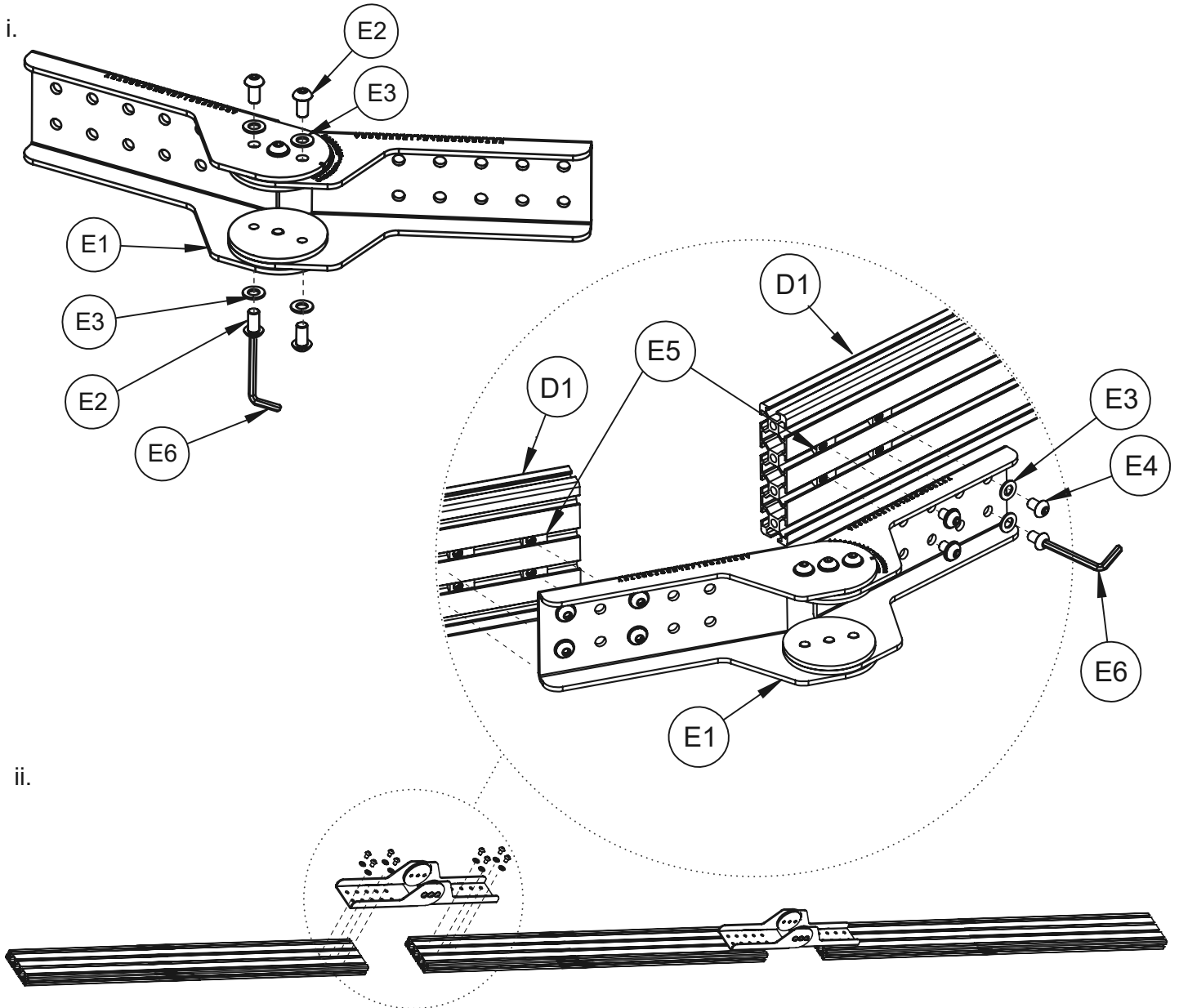

***Note:** The rail fixing positions to use on item E1 are dependent on the size of screens being used.

For help with the rail fixing position contact:
technical@btechavmounts.co.uk

Please state the screen size, screen depth, rail length and curve angle of the installation.

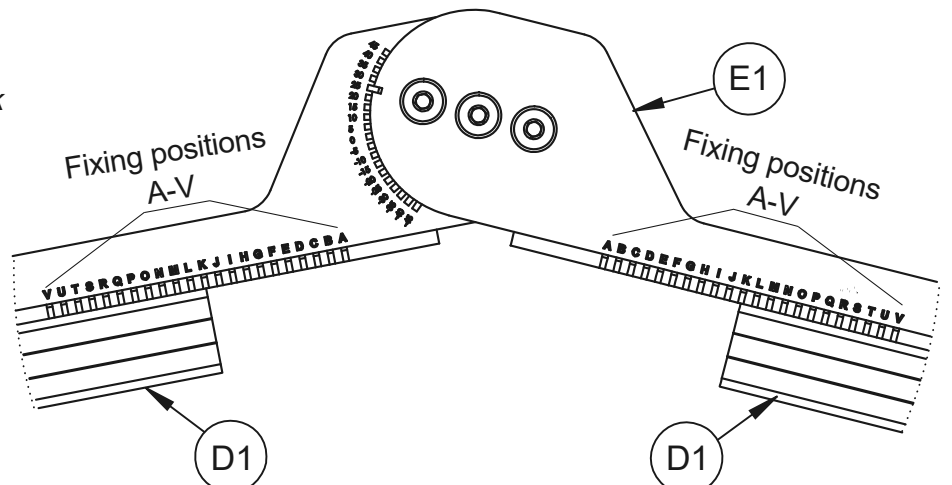

4

Attach Columns to Rails

On the floor, lay item B1 onto item D1. Attach item C1 to item D1 by fastening item C3 into the inserted items C2.

To ensure straight assembly of item B1 make sure the distance of items C1 to the end of item D1 are set the same on each rail.

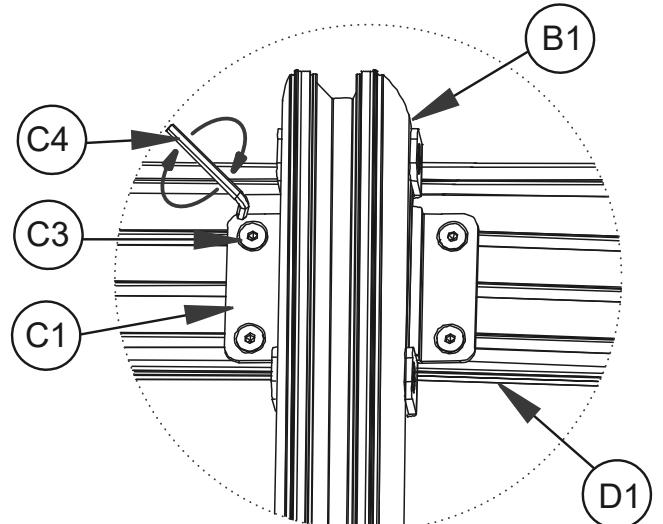
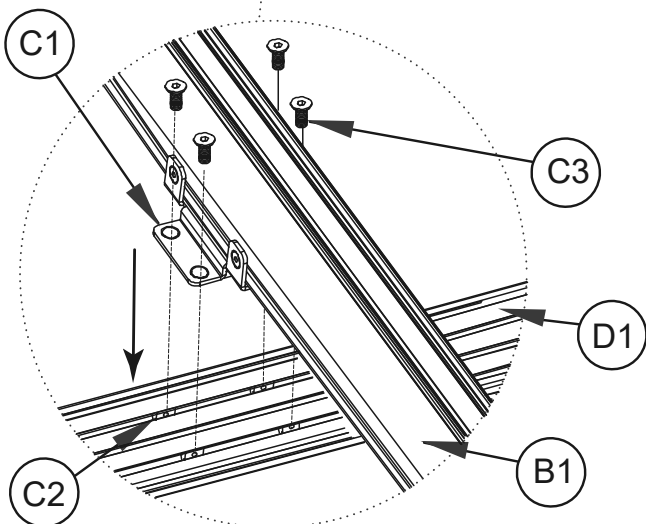
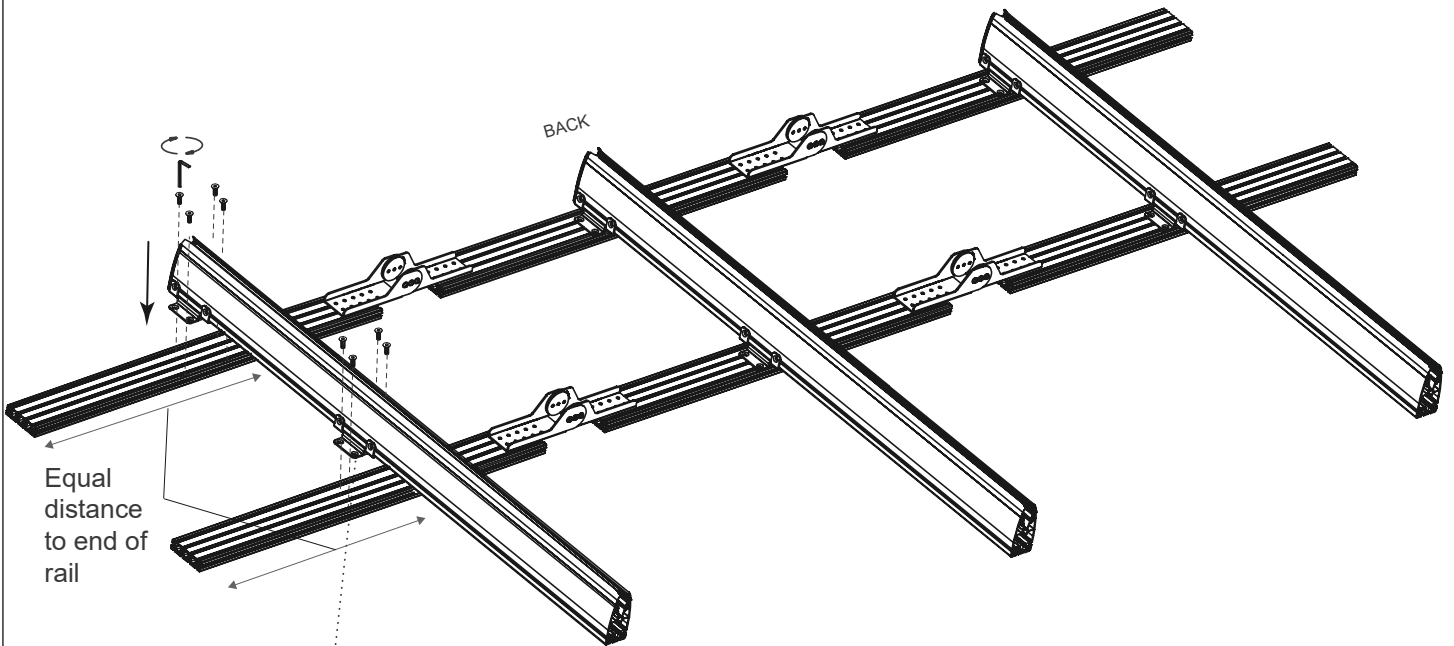
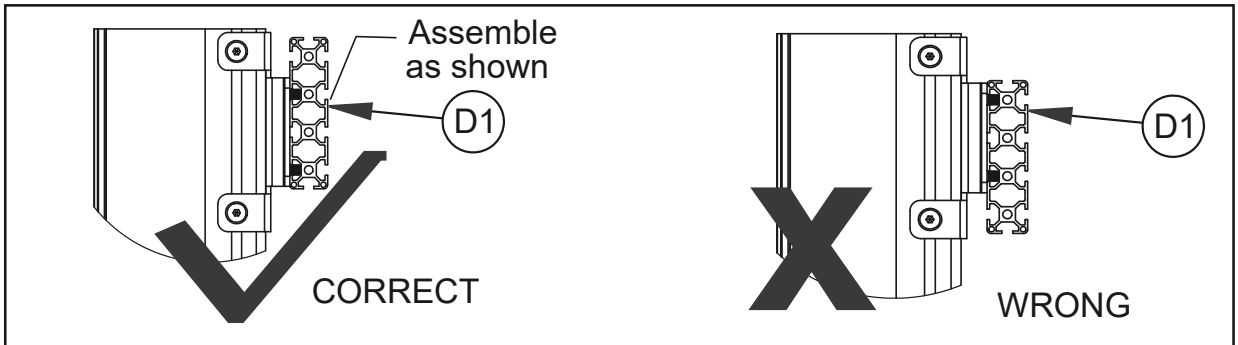

5

Assemble Bases to Columns

Attach item A1 to item B1 using items A3, A4 & A5.

Once bases are fixed to columns, return stand to upright position.

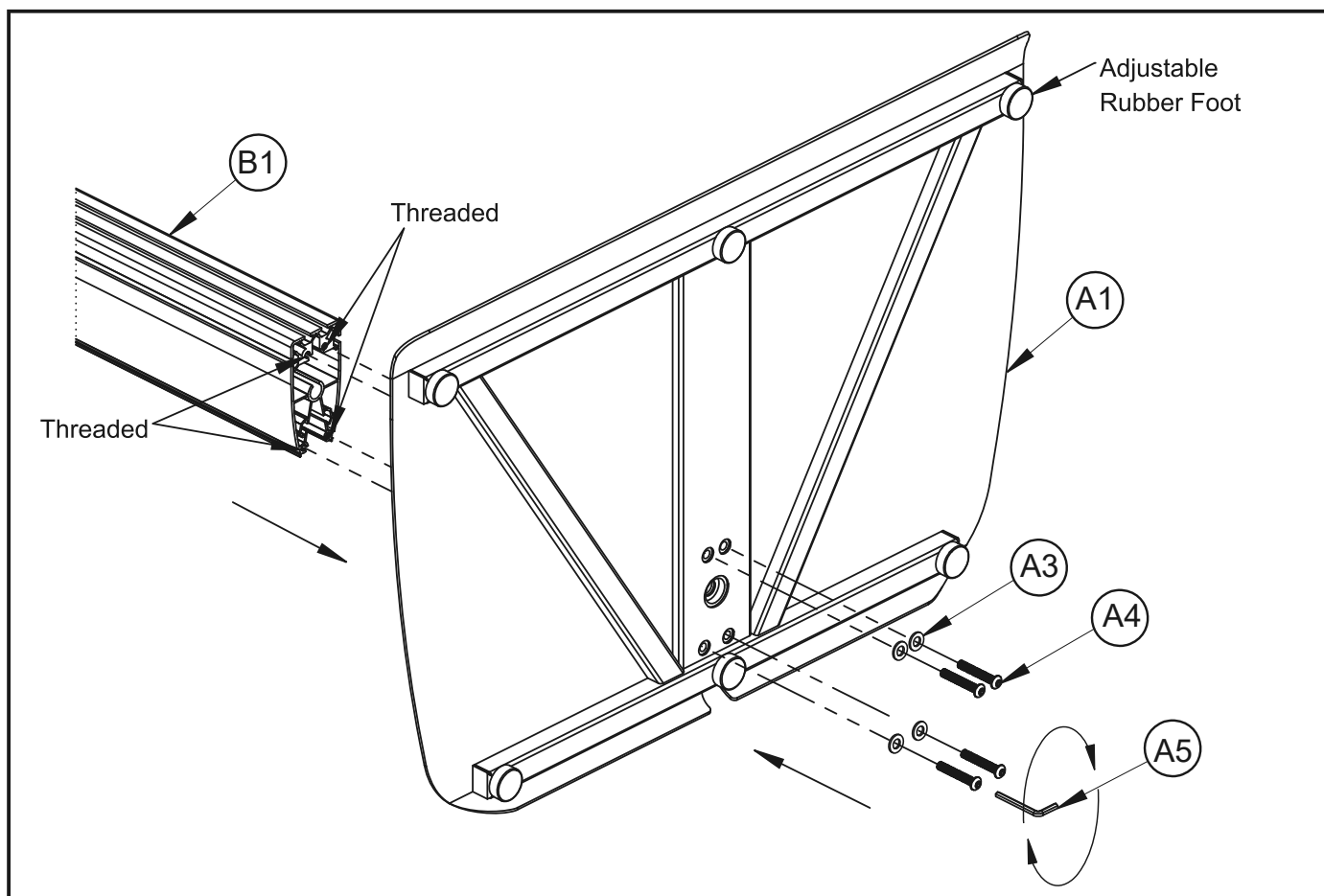
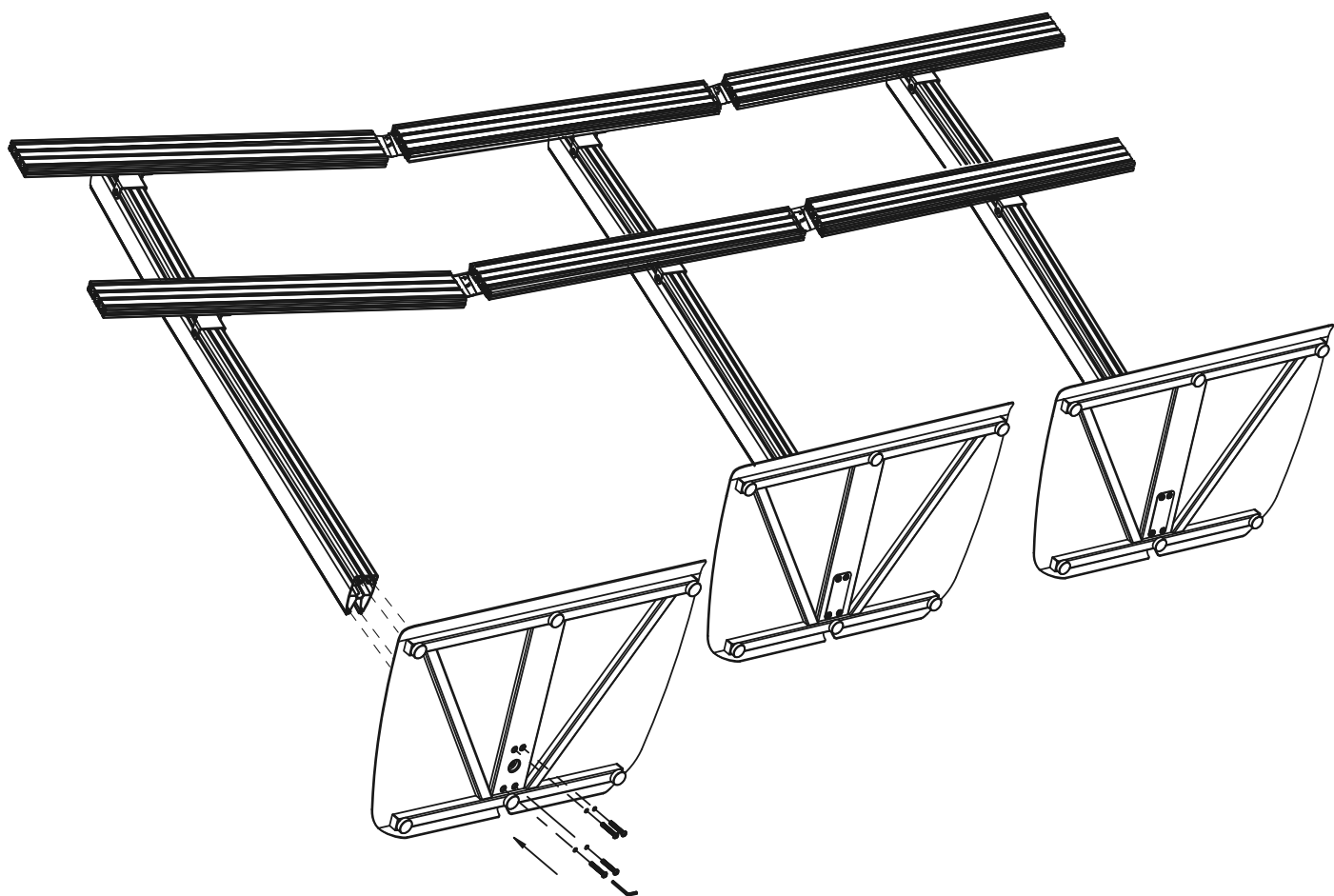

6

Fix Angle

Set the angle required on item E1 and fully tighten all screws with item E6.

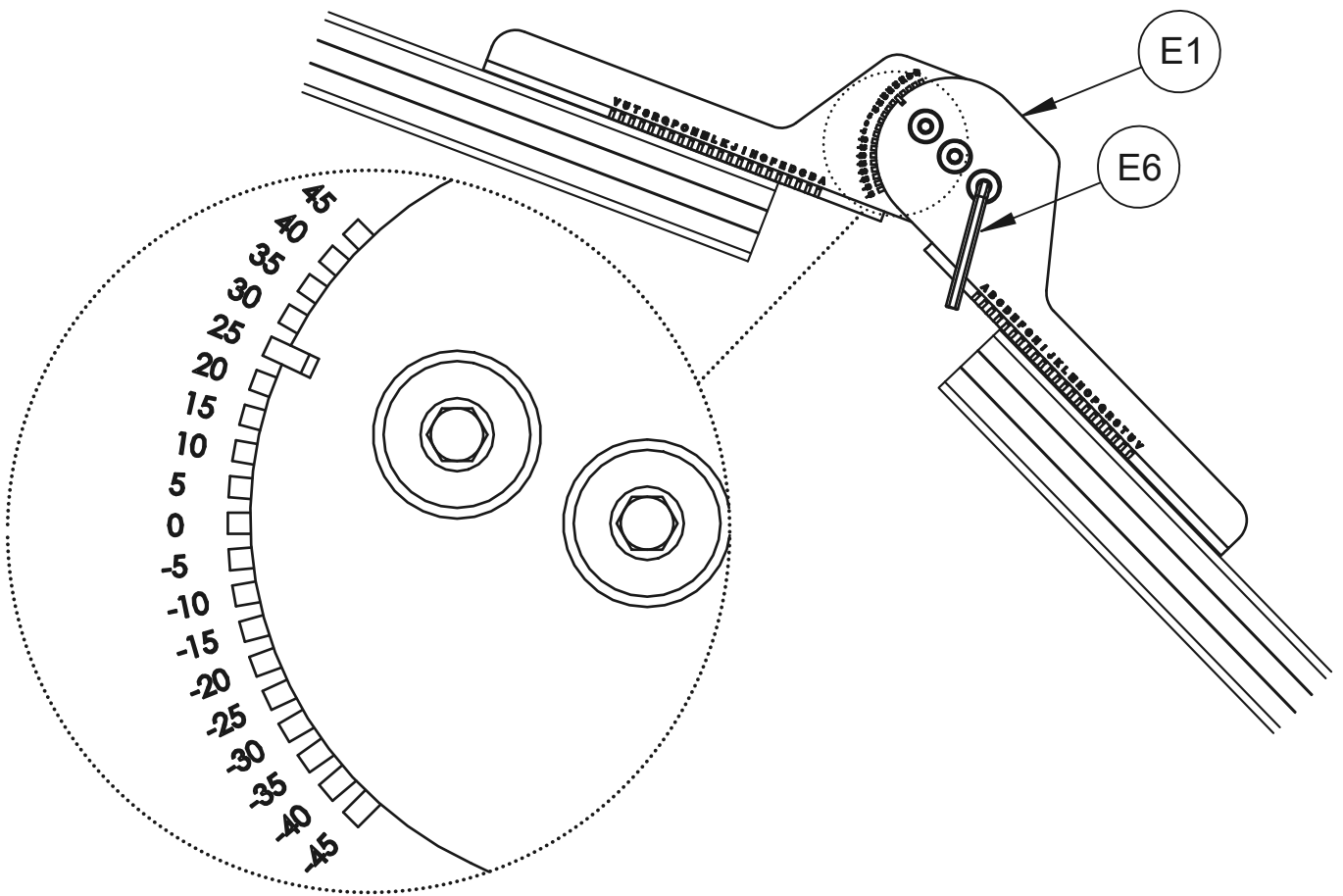
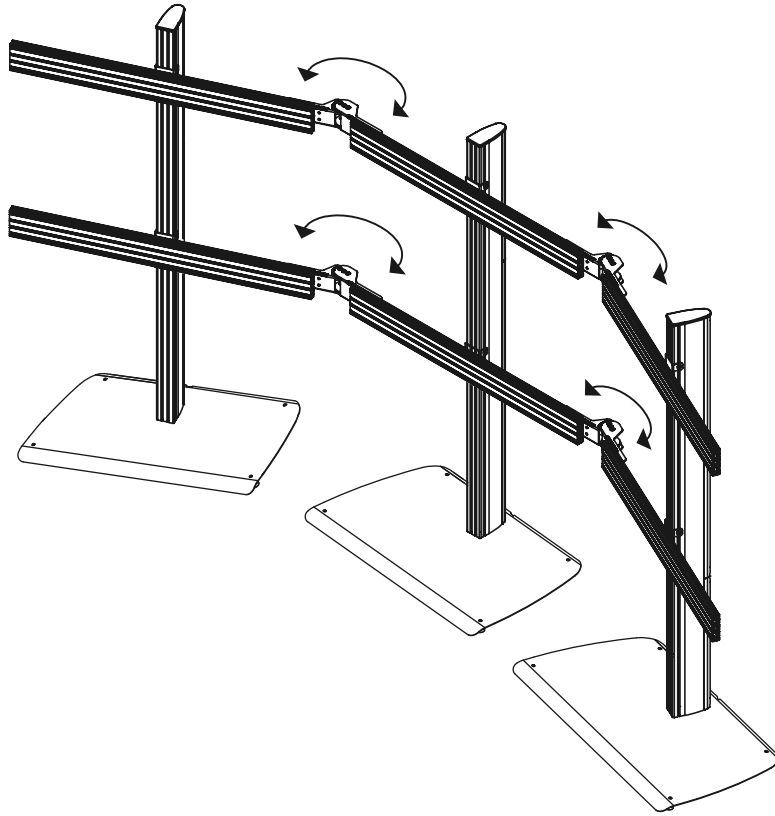

7A

Attach Interface Arms to Screen (BT8390-VESA400MAF Arms)

Attach items G1 & G2 to the back of the screens using items A-F.

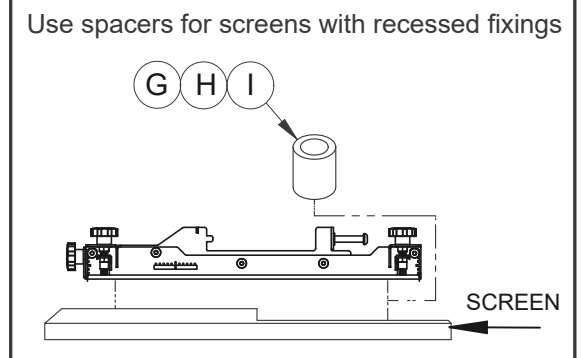
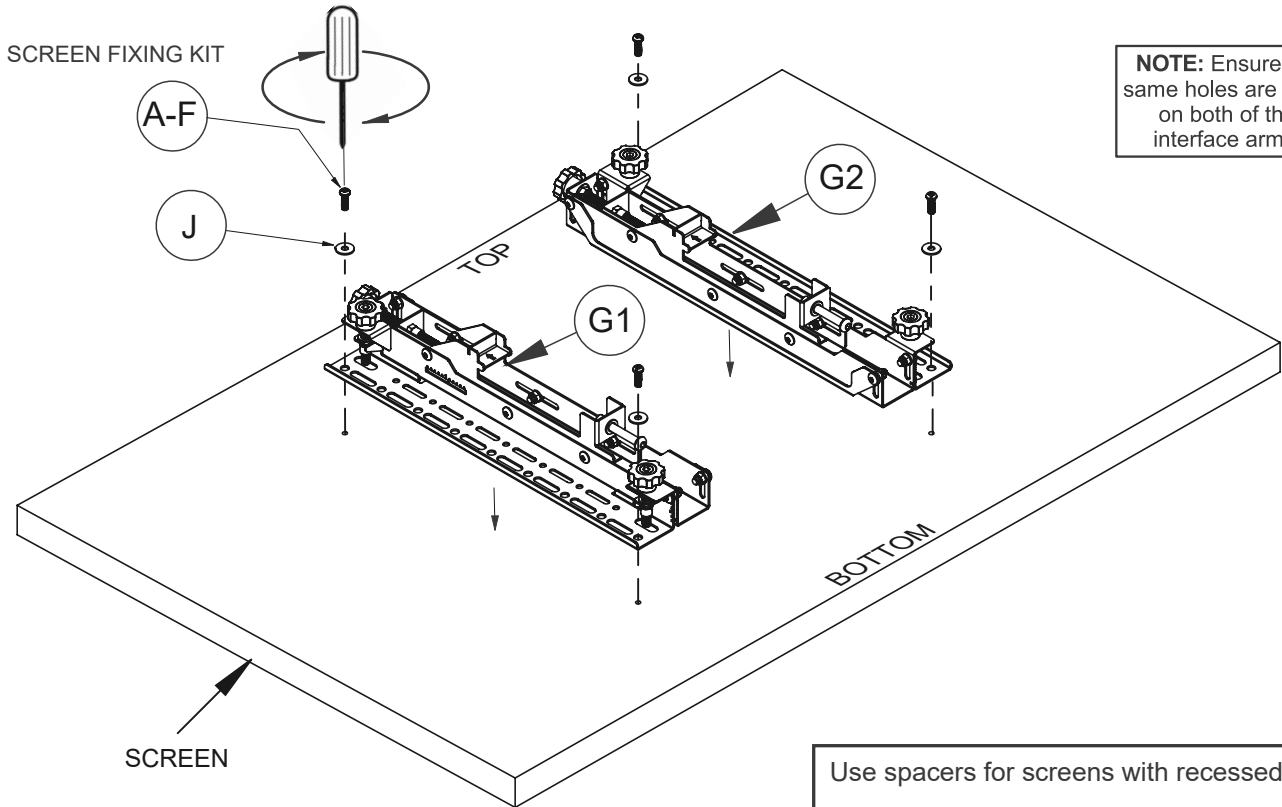

Using Interface Adaptor Arms

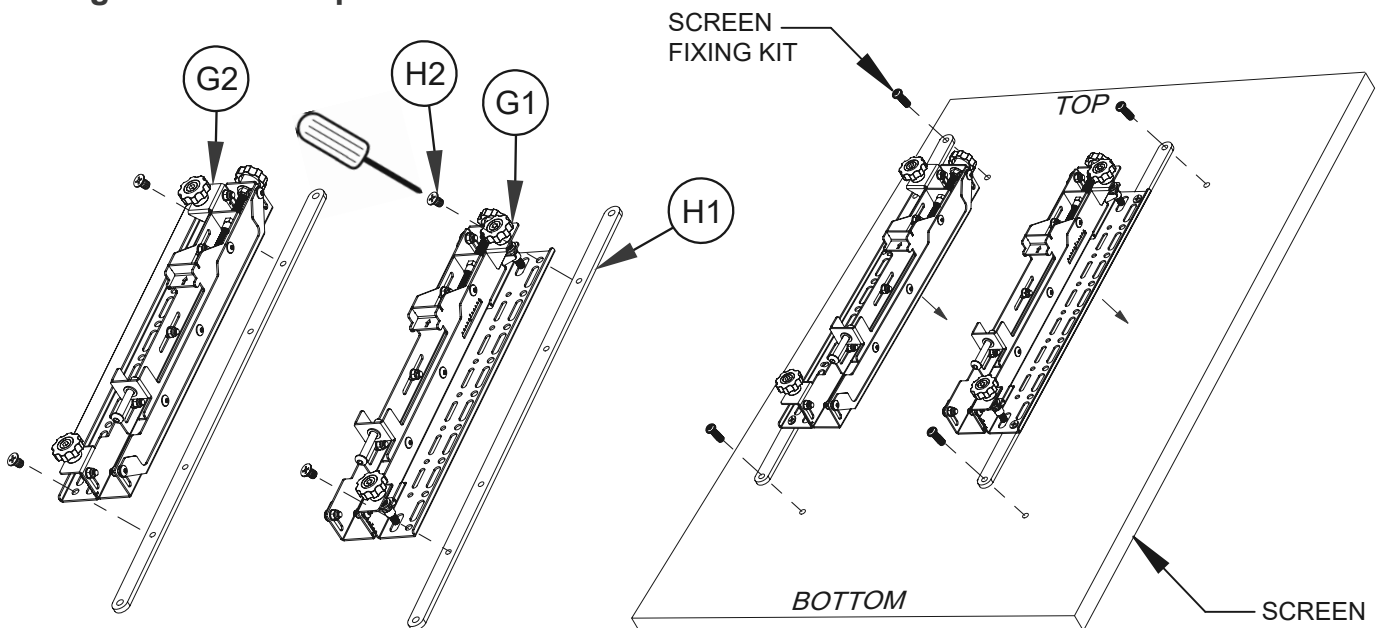

NOTE: Portrait mounting shown.
For landscape mounting attach adaptor arms horizontally

8A

Hook Screen onto the Stand

Hook the first screen centrally onto the bottom rail and align screen with the horizontal centre of the trolley / stand

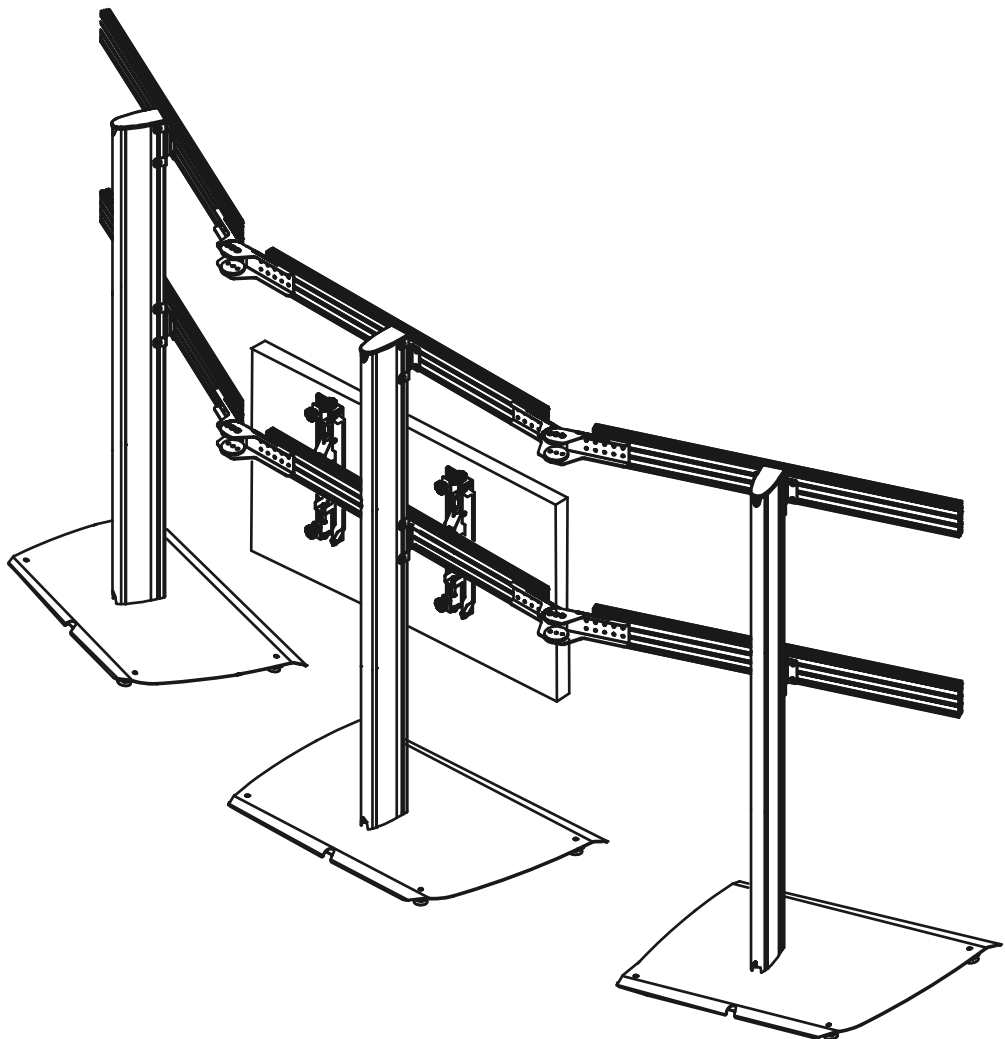
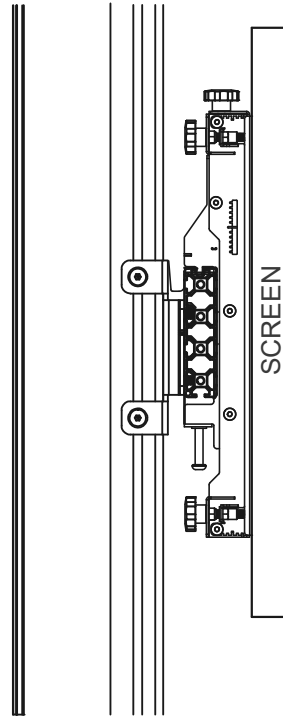
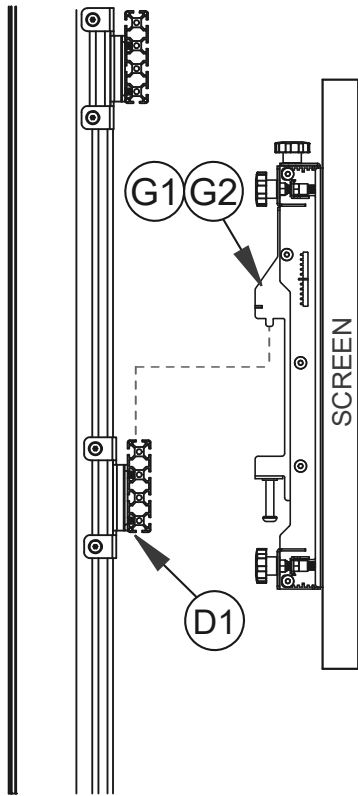

Attaching Pop-Out Interface Arms to Screens (BT8390-VESA400MAP Arms)

i. Attach items G1 & G2 to the back of the screens using items A-F.

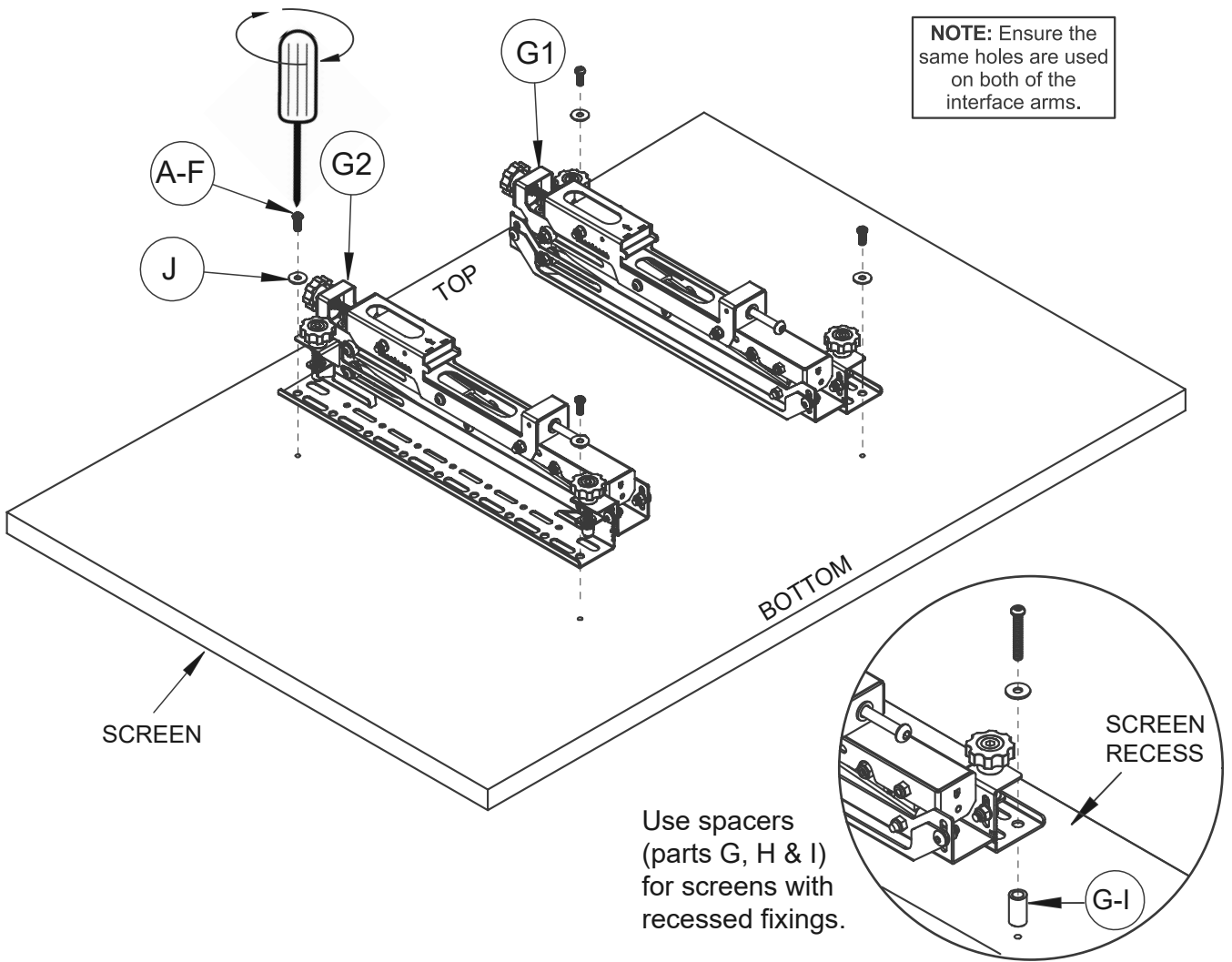

ii. Connect interface arms with the adjustable brace.

Extend item G3 and fix at desired length by tightening the 2 screws.

The 3 notches show the position for interface fixings at 400mm, 500mm and 600mm.

Note: The adjustable brace (part G3) is only suitable for horizontal VESA fixings from 400 - 600mm.

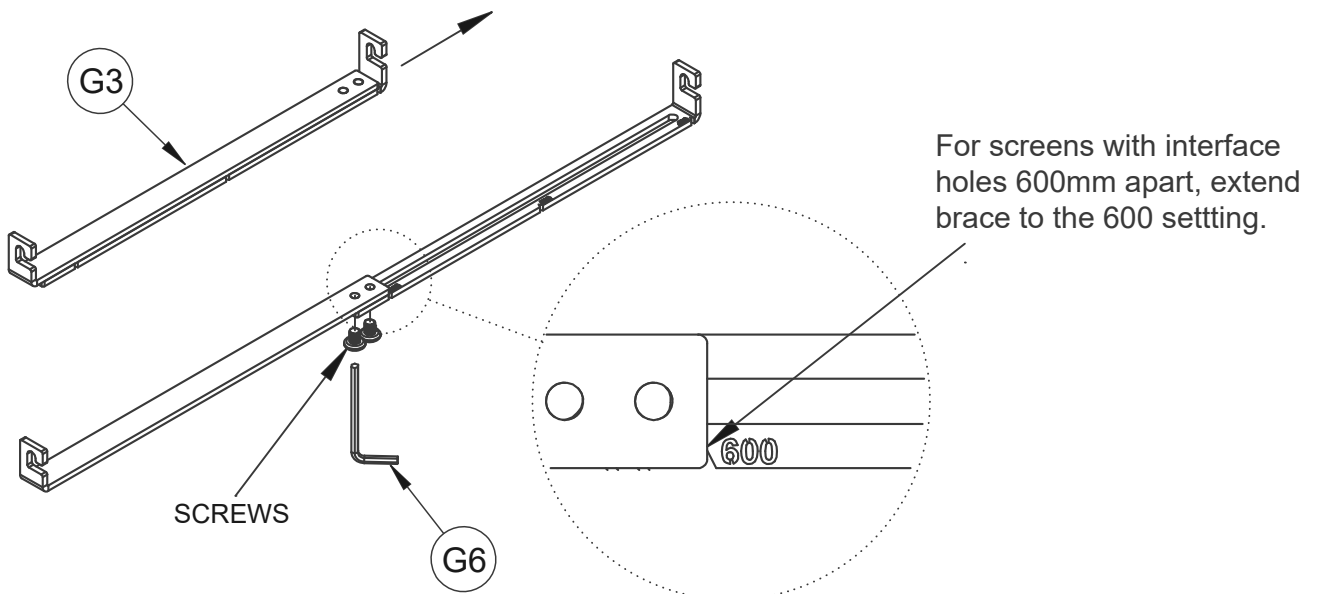

iii. Fix item G3 to items G1 & G2 for easy lateral adjustment of screen.

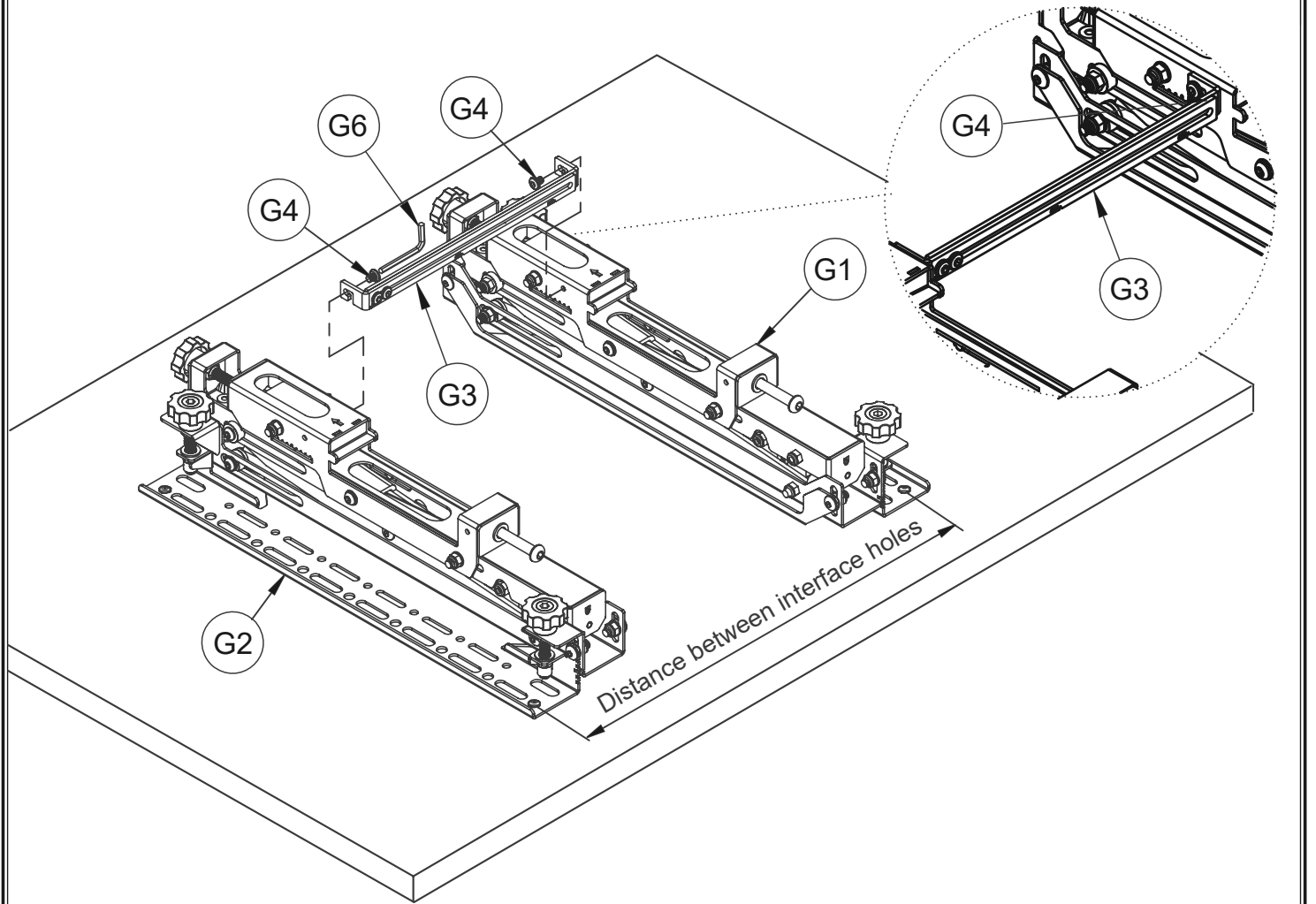

8 B

Hook Screen onto the Stand

Hook the first screen centrally onto the bottom rail.

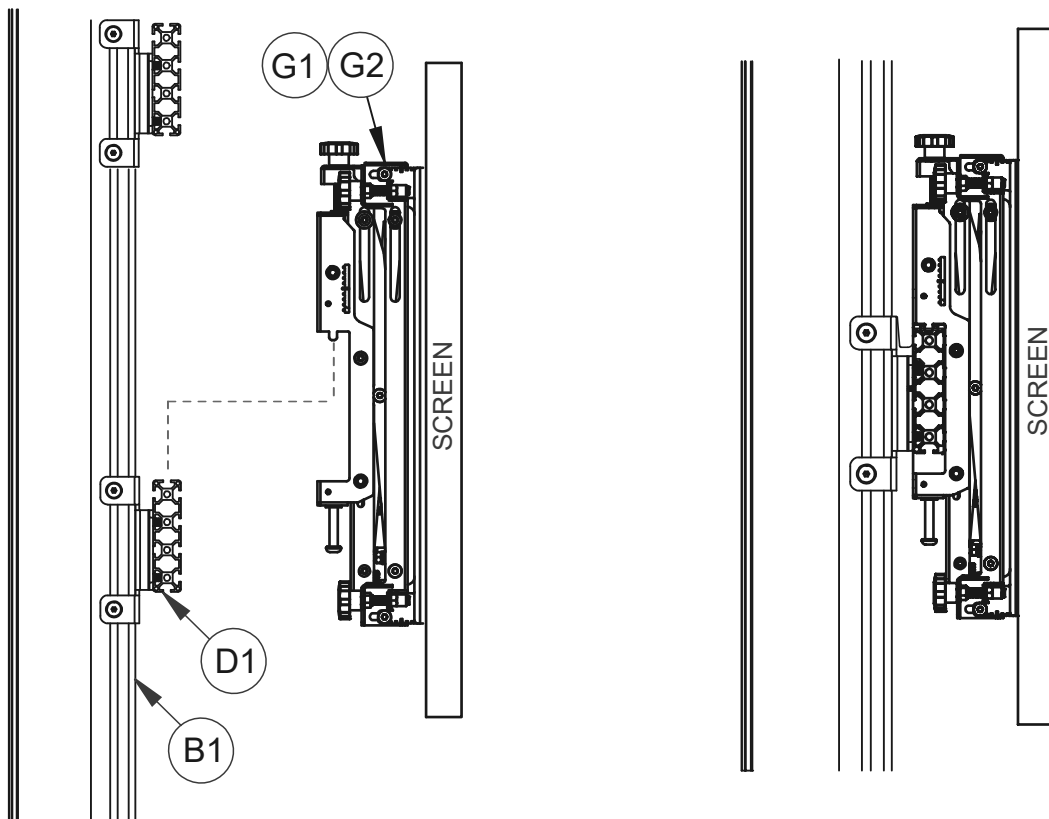

Align screen

- i. After mounting each screen use the micro-adjustment knobs on the interface arms to level and align screen.

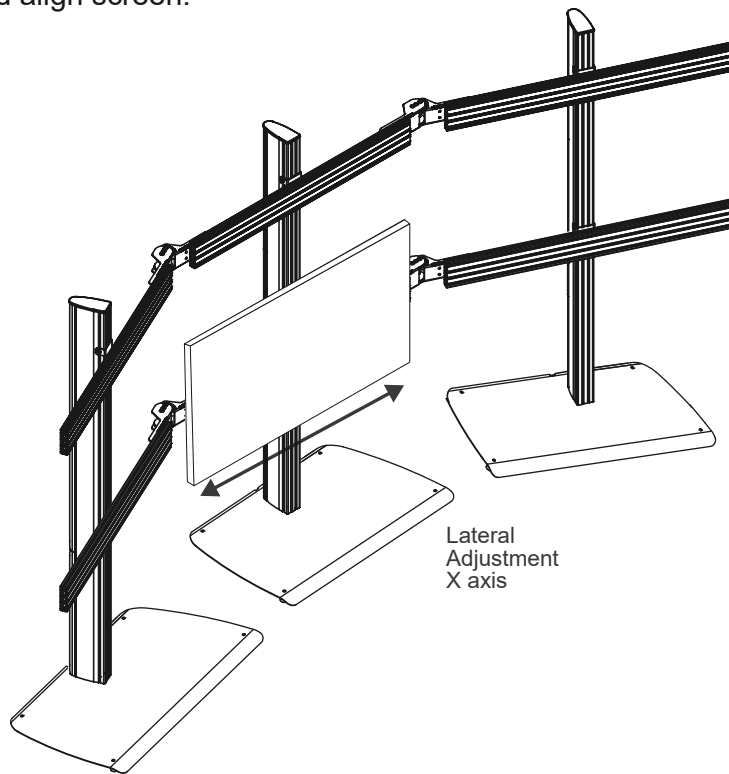

-
- ii. Hook on the remaining flat screens and align screens accordingly.

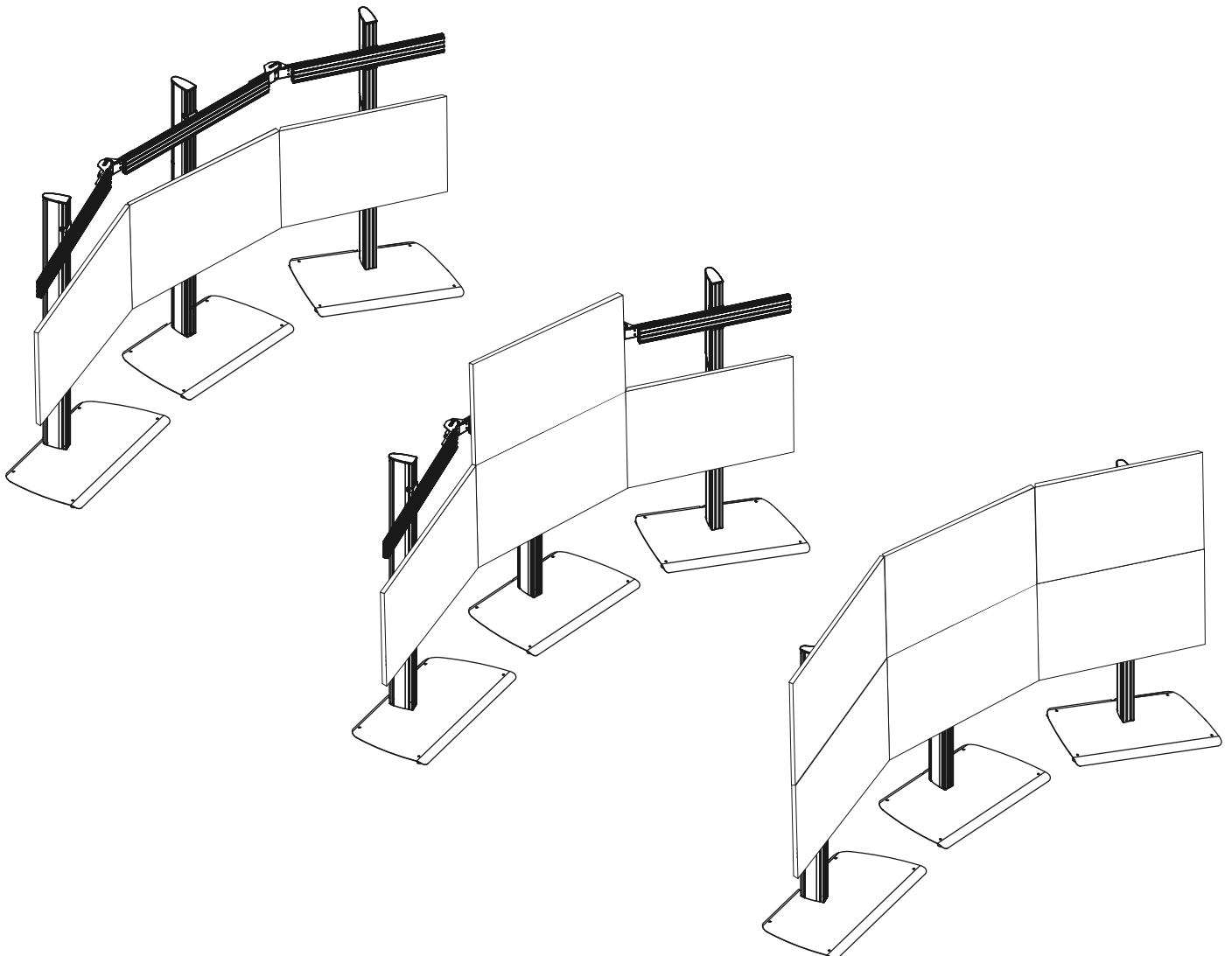

Align Screens using Micro-Adjustment

- i. Align the flat screen to the floor using the height adjustment knobs.
- ii. Use the depth adjustment knobs to ensure flat screen is perpendicular with the floor and to ensure that each corner of the screen is aligned evenly.

Micro-adjust top row first and work down row by row.

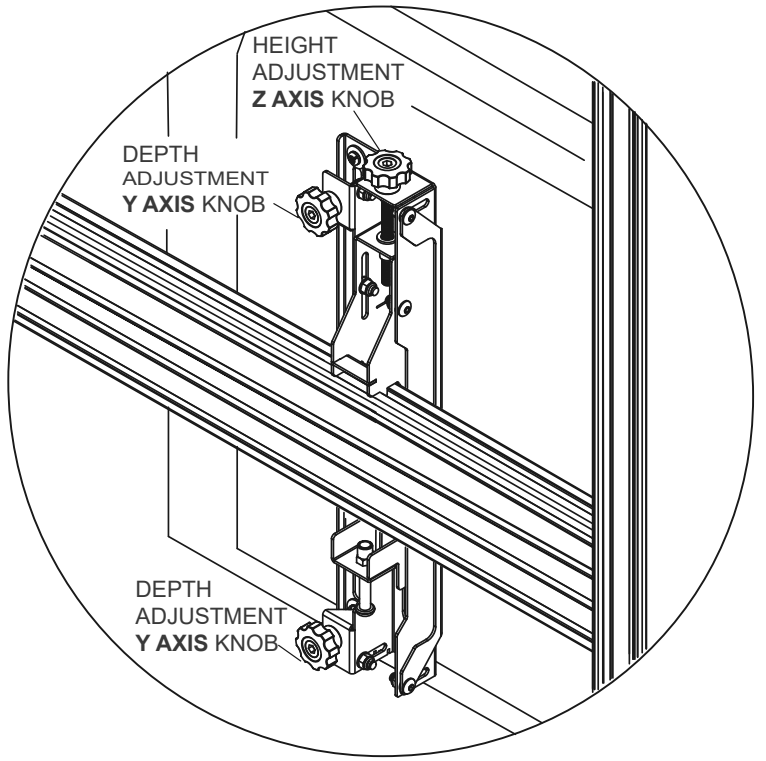
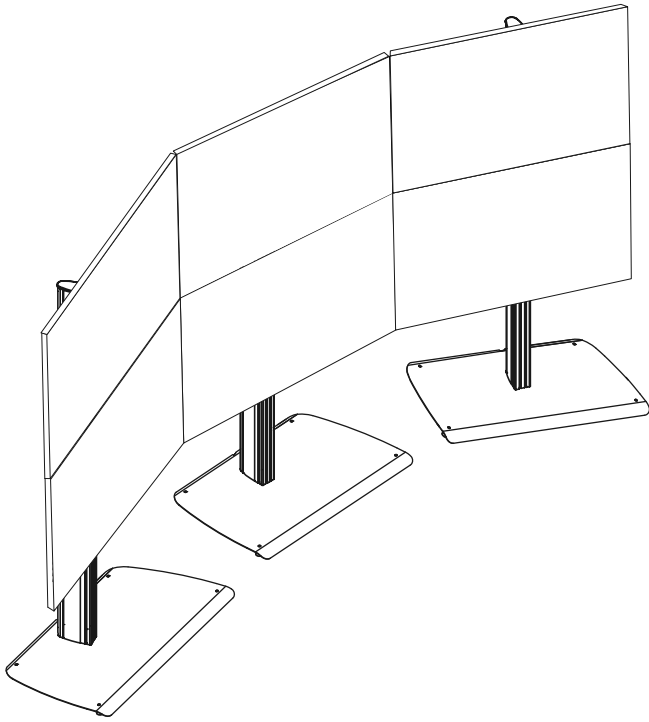

Use Depth Adjustment
(Y axis knobs) to align front of screens

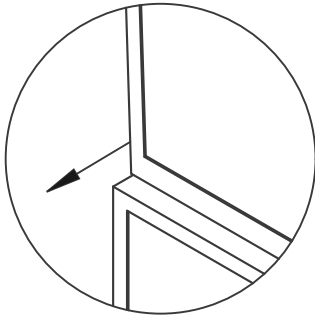

Use Lateral Adjustment
to align sides of screens

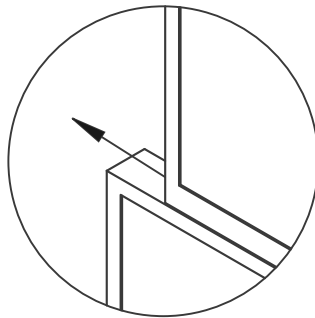

Use Height Adjustment
(Z axis knobs) to align bottom/top of screens

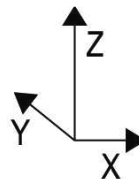
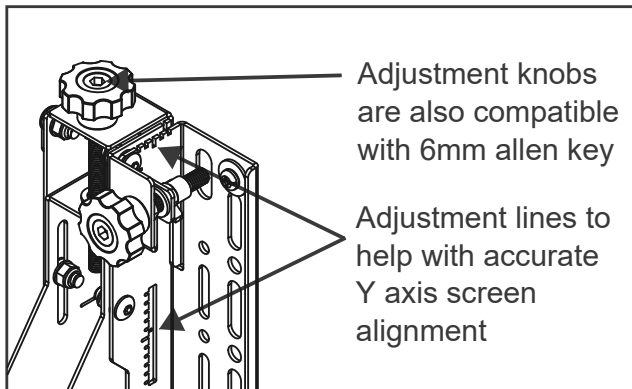
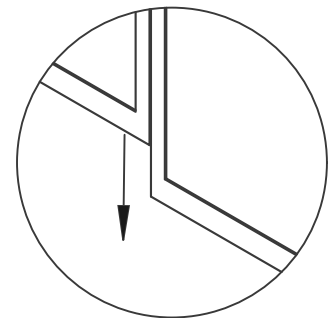

Note: Light pressure in the desired direction of travel will assist in the adjustment of knobs when using heavier screens

BT8390-VESA400MAF
Total Y axis adjustment is 20mm
Total Z axis adjustment is +/-25mm

BT8390-VESA400MAP
Total Y axis adjustment is 20mm
Total Z axis adjustment is +/-20mm

1 1

Secure Screens

Once screens are aligned, tighten the safety screws on the bottom items G1 & G2.

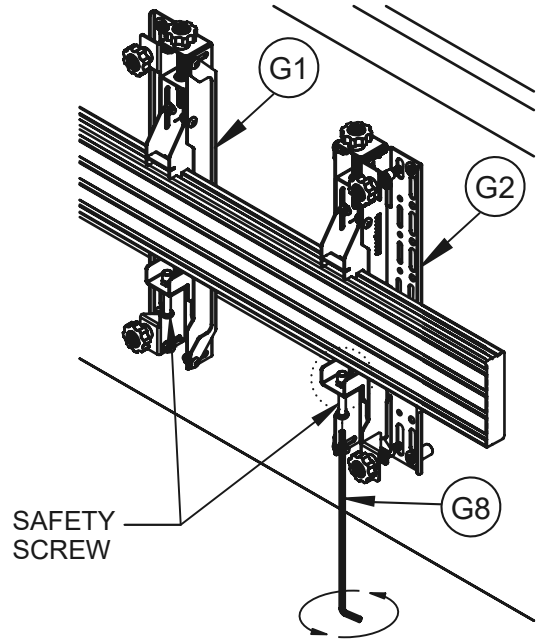
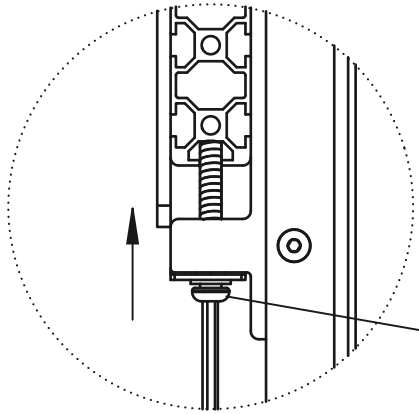

1 2

Servicing Screens (Pop-Out Arms only)

Push centrally at the left and right of the screen to pop-out the mount. The screen will rest in the 'open' position for servicing.

Note: Ensure pop-out function is not disabled (see below).

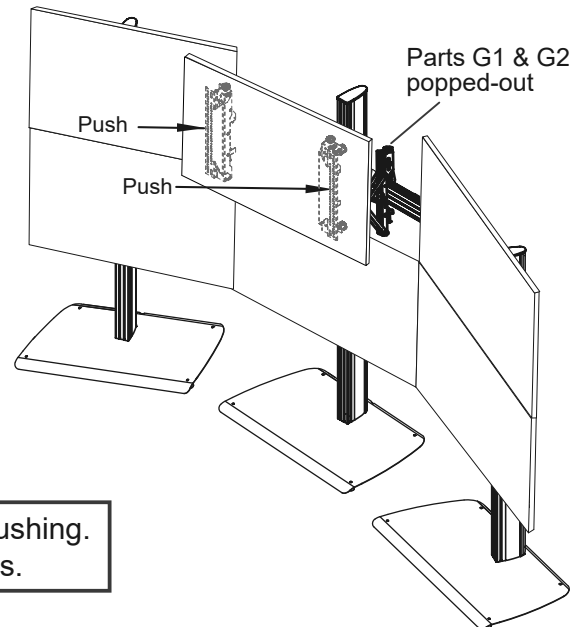

IMPORTANT: Be careful not to damage the screen when pushing. Keep hold of the screen as it moves outwards.

Disabling Pop-Out Function (optional)

To prevent interface arms from popping out, fully insert and tighten item G5 at the padlock* symbol at the bottom of items G1 & G2.

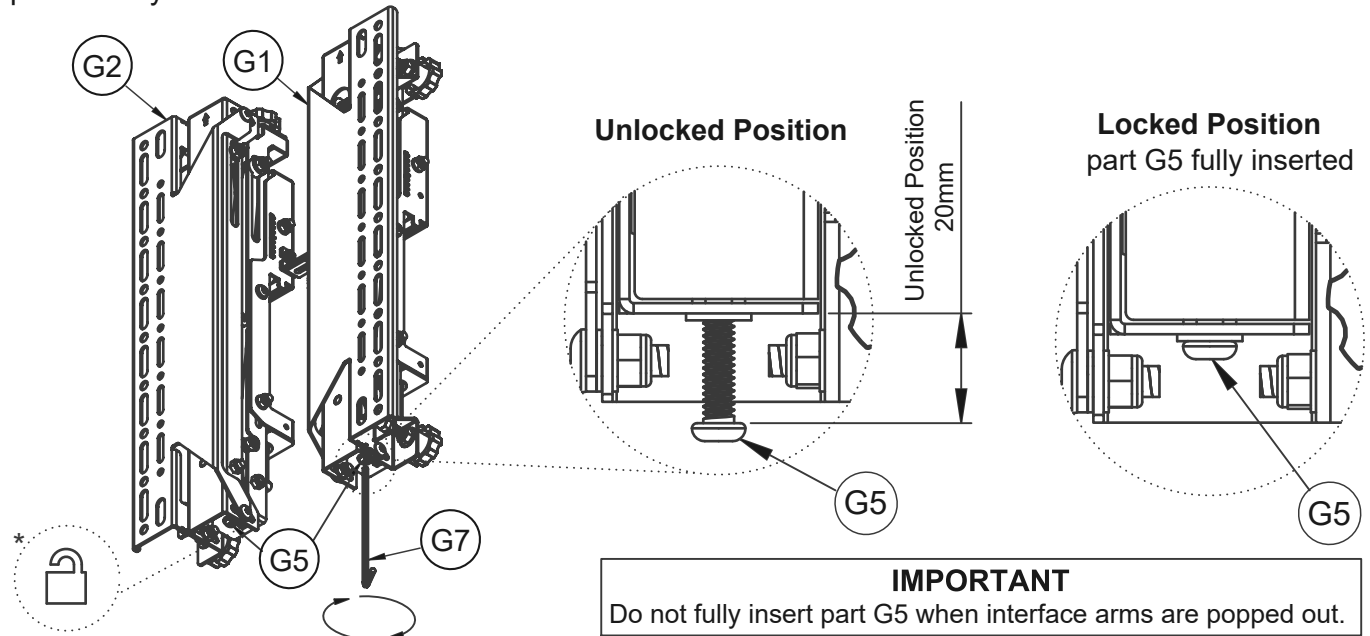

IMPORTANT
Do not fully insert part G5 when interface arms are popped out.

Add End Caps & Cable Management Covers

- i. Once all the screens and power cables are connected and if possible routed down the backs of item B1, partially clip on items B3, this allows easy removal if more cables need adding. Once satisfied all cables are fitted, clip items B3 on fully.
- ii. Fit items D2 to items D1.
Fit items B2 to items B1.
- iii. With a knife, cut to length items B4 and slot into the front and sides of item B1.

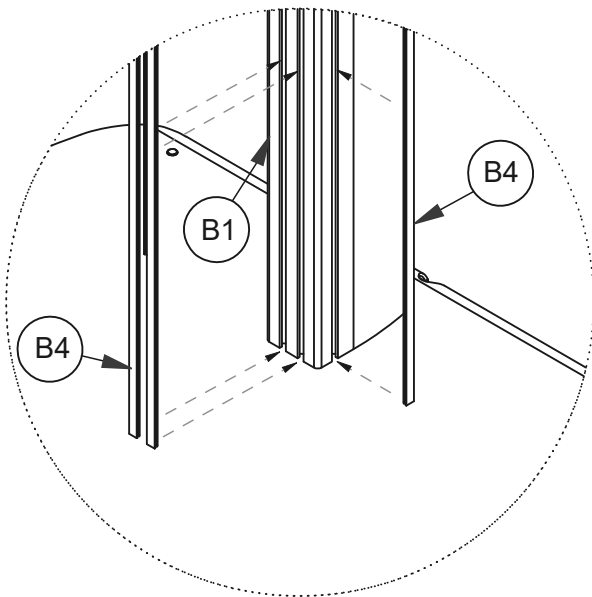

- iv. If bolting down the stand, remove item A2 and rubber feet from A1 and fix base to the floor using suitable floor anchors.

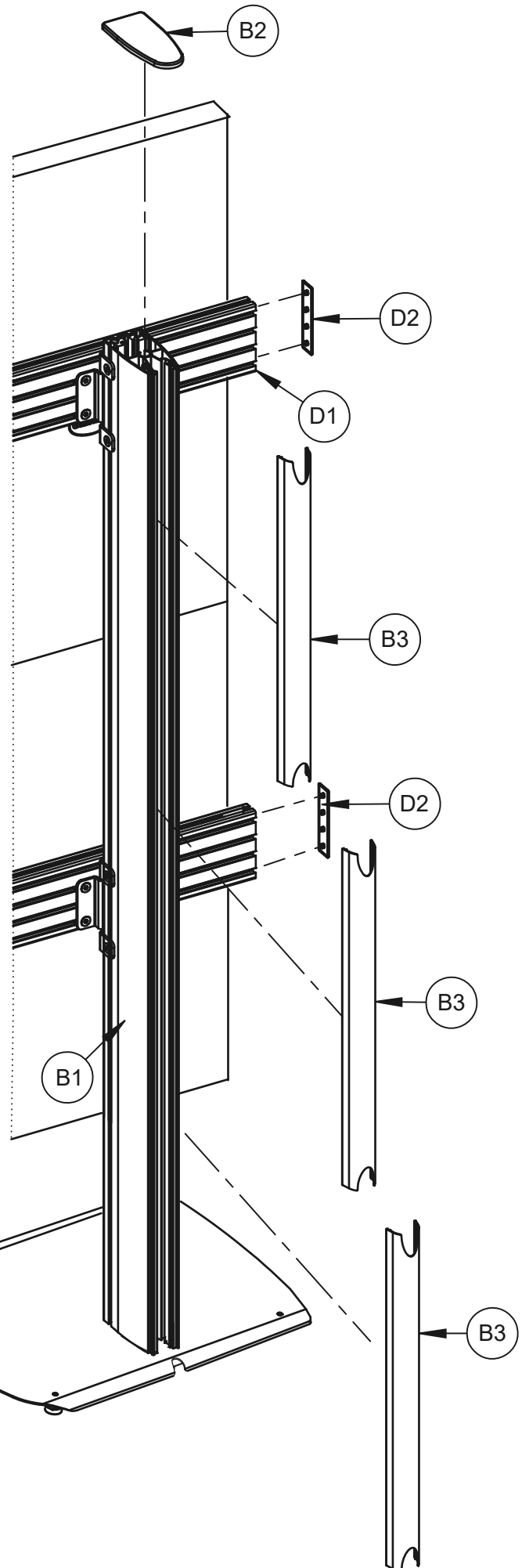
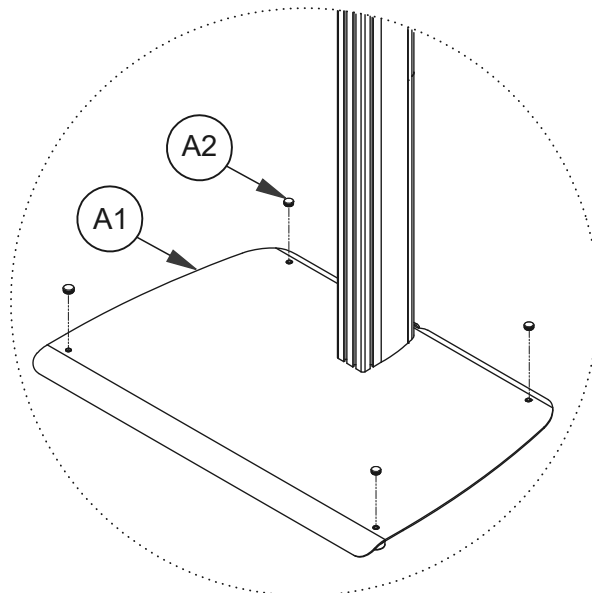

PRODUCT DIMENSIONS

BASE AND INTERFACE ARMS

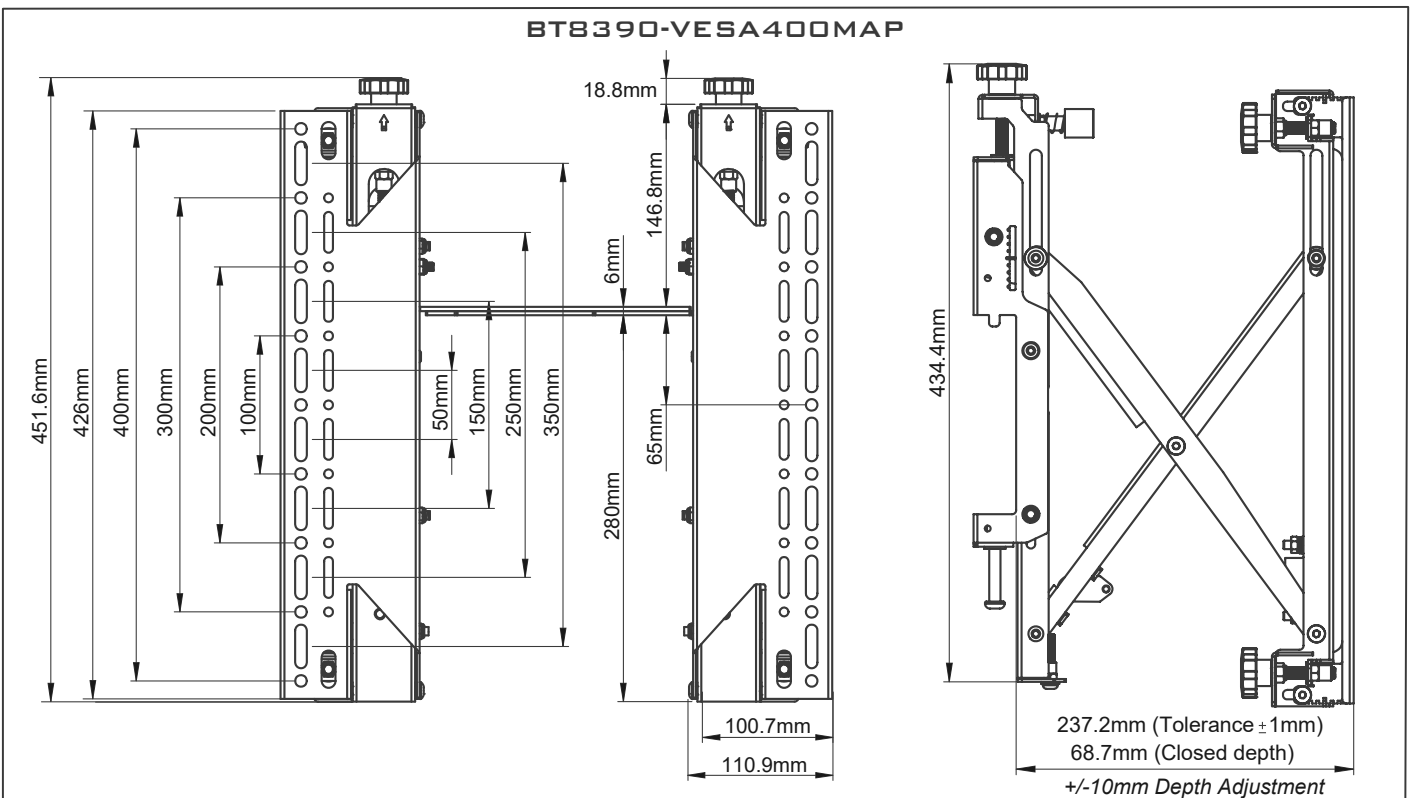
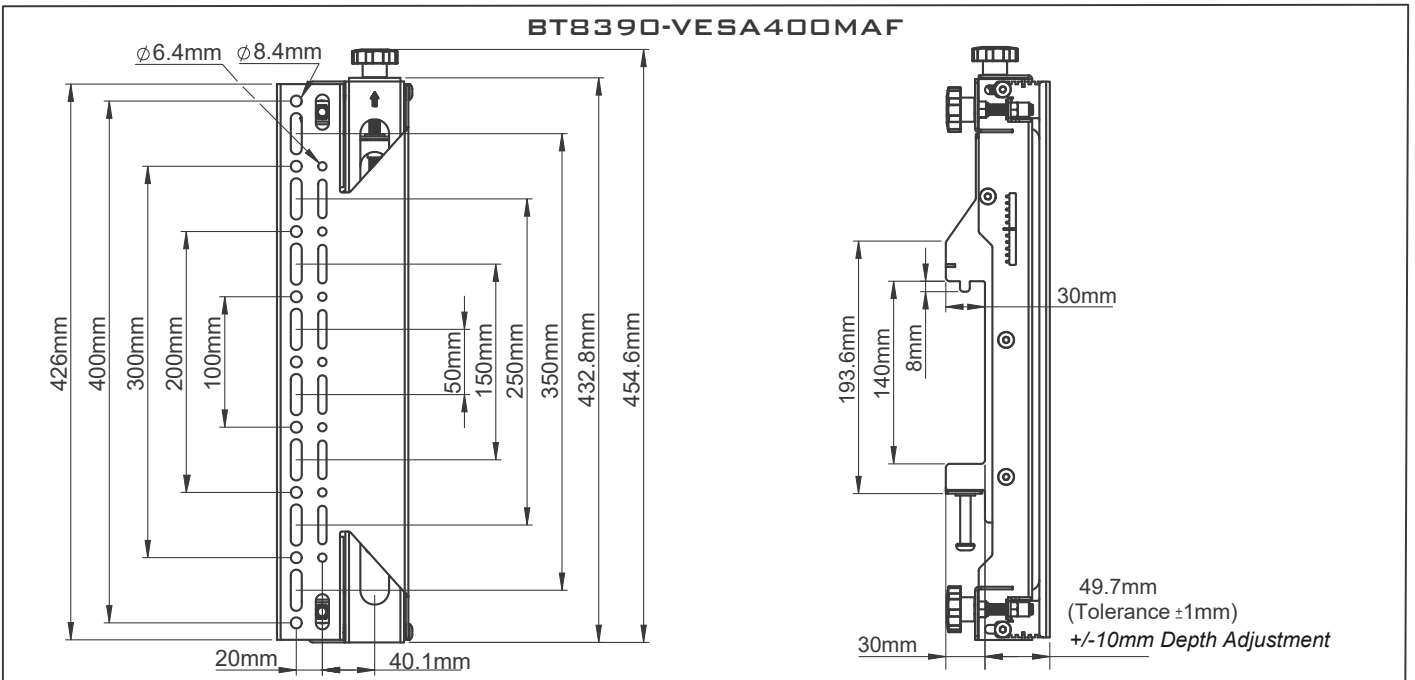
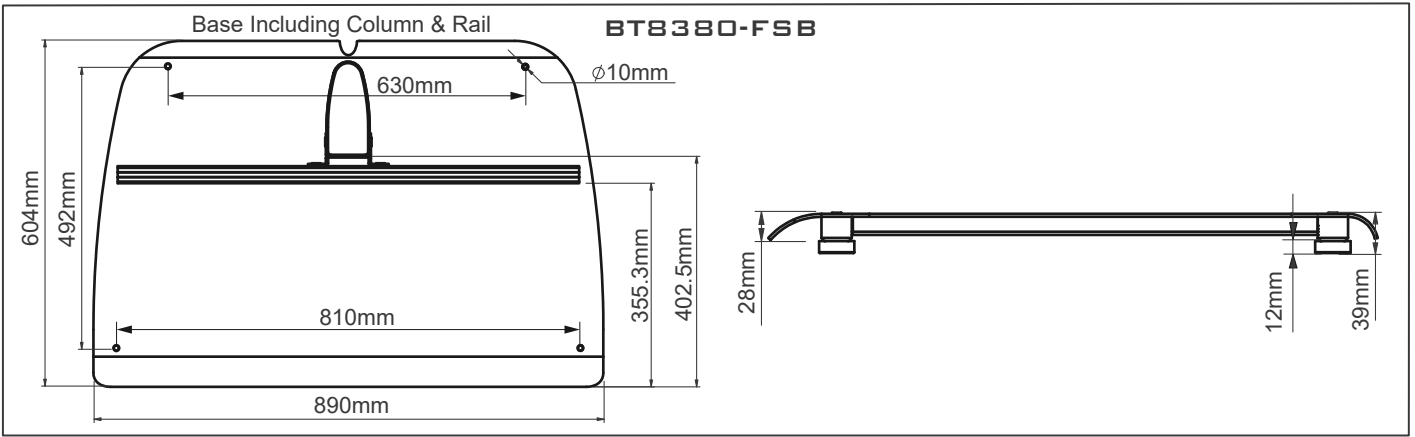

THESE DIMENSIONS ARE INTENDED AS A GUIDE ONLY AND
B-TECH ACCEPTS NO LIABILITY FOR THE ACCURACY OF THE INFORMATION



www.btechavmounts.com

B-TECH AV MOUNTS

HEAD OFFICE

B-Tech International Limited

Bennett House, Long March, Daventry, Northants., NN11 4NR, UK

Email: info@btechavmounts.com

©2019 B-Tech International Design and Manufacturing Limited. All rights reserved.

B-Tech AV Mounts is a division of B-Tech International Design & Manufacturing Ltd.

B-Tech, Better By Design & System X are registered trademarks of B-Tech International Design & Manufacturing Ltd.

All other brands and product names are trademarks of their respective owners.

Photographs are for illustrative purposes only. E&OE.

AMA-BT8376-V1.1-0819-BTECH MADE IN VIETNAM